

GTZ SERIES

Multi-tasking Turning Centers

www.YAMASEIKI.com



YAMA SEIKI[®]
TURNING CENTERS by **WOODWAY**[®]

Brand New Multi-Tasking Machining Technology

- New twin spindle and twin turret combination
- Upper and lower turret can be adjusted based on different machining requirements
- Production capacity is **1.5** times larger than average models

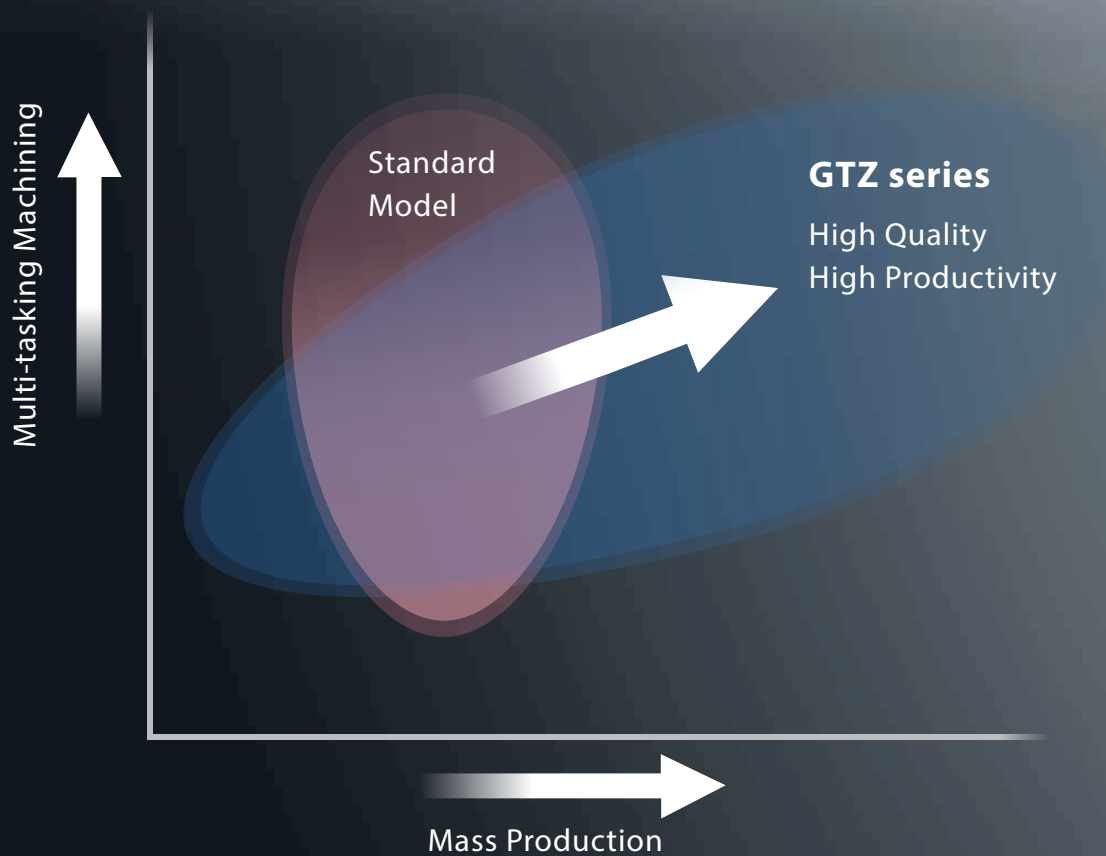



GILINC 350

GOODWAY

3D CHECK

PLAN	REL	ABS
X		
Y		
Z		

MACH DIST

PLAN	REL	ABS
X		
Y		
Z		

MACH DIST

PLAN	REL	ABS
X		
Y		
Z		

3D CAD model of a mechanical part with a 3-axis coordinate system (X, Y, Z) overlaid.

Keyboard with function keys (G, F, M, S, T, 7, 8, 9, X, Z, C, Y, B, 4, 5, 6, A, S, D, F, G, H, J, K, L, U, I, O, P, Q, W, E, R, T, Y, U, I, O, P, L, W, H, V, N, M, 1, 2, 3, 4, 5, 6, 7, 8, 9, 0, ., /, +, =, -, =, <, >, [,], {, }, ~, `) and a numeric keypad.

Control console with emergency stop (red button), speed override knob, tool selection knob, and various function buttons (F1-F5, X, Y, Z, A, B, C, +, -). Includes a key lock and a rotary dial.

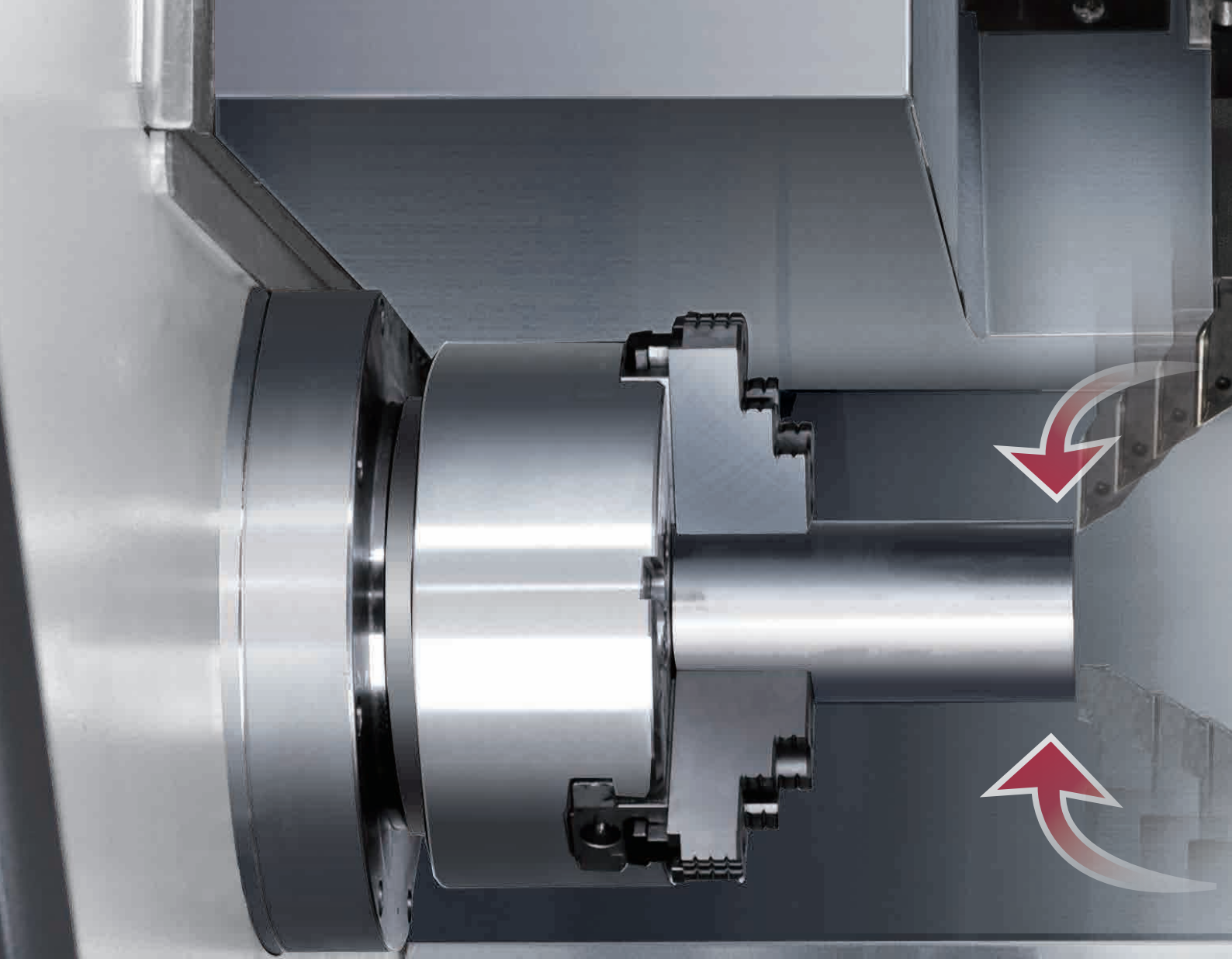

▶ Upper turret working on left spindle
Lower turret working on right spindle

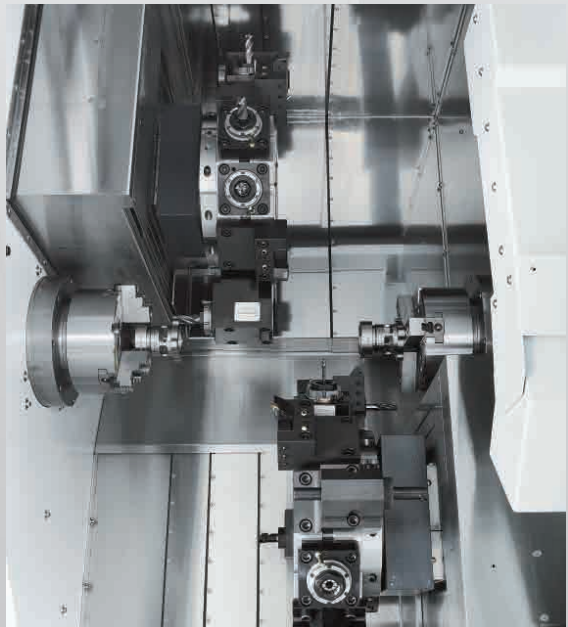

▶ Upper turret working on right spindle
Lower turret working on left spindle

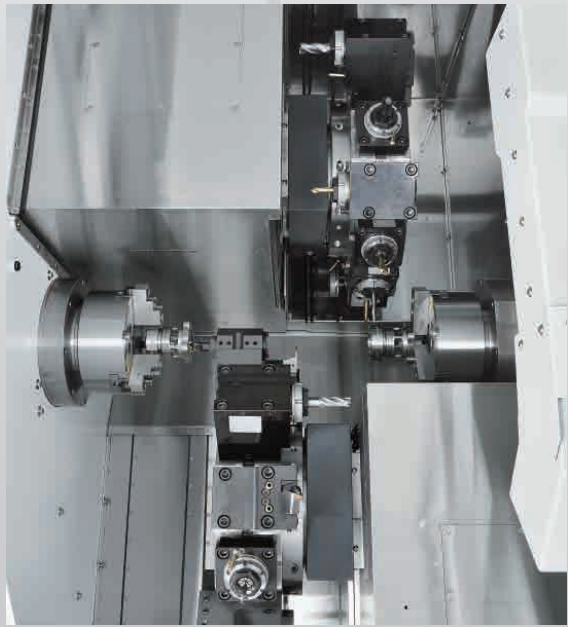

Flexible Machining Combinations

- ▶ Work-piece can be moved between both spindles

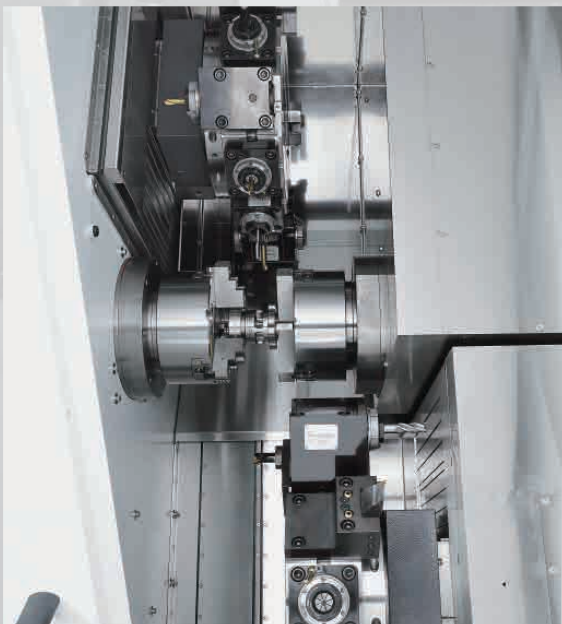

- ▶ Both turrets can work on the work-piece simultaneously

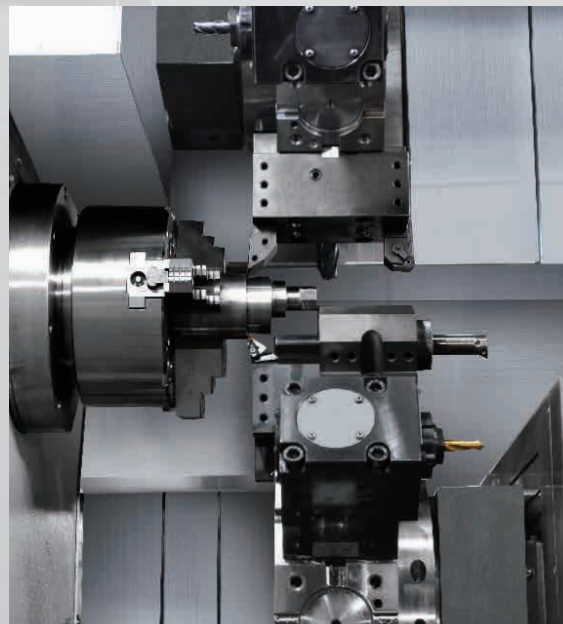

SUPER RIGIDITY STRUCTURE

The low center of gravity 45° slant bed design provide a super rigid foundation for the headstock and turret.

By using Finite Element Analysis (FEA), optimal reinforced ribbings are directly cast into the one-piece bed structure.

1st Spindle

- Chuck size : 6" (Big-bore) / 8" (Big-bore)
- Bar capacity : Ø 51 / Ø 65 mm
- Motor output : 11 / 15 kW (cont. / 30 min)
- High resolution Cs-axis close-loop control system

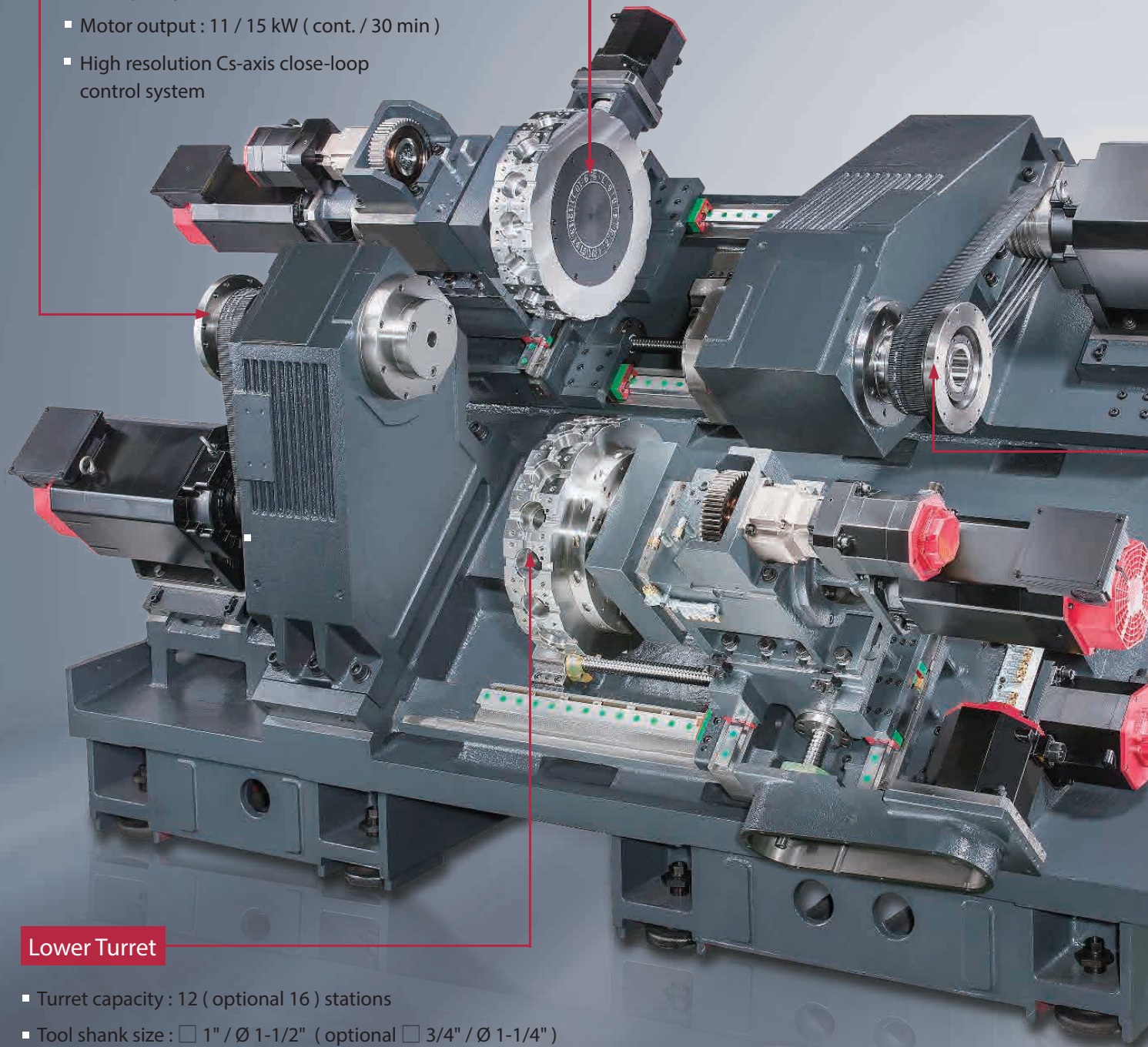

Lower Turret

- Turret capacity : 12 (optional 16) stations
- Tool shank size : □ 1" / Ø 1-1/2" (optional □ 3/4" / Ø 1-1/4")
- Live tooling shank size : ER32 (optional ER25)
- Live tooling output : 3.7 / 5.5 kW (cont. / 30 min)
- Flexible turret combination can support twin spindle machining

Upper Turret

- Turret capacity : 12 (optional 16) stations
- Tool shank size : □ 1" / Ø 1-1/2" (optional □ 3/4" / Ø 1-1/4")
- Live tooling shank size : ER32 (optional ER25)
- Live tooling output : 3.7 / 5.5 kW (cont. / 30 min)
- Flexible turret combination can support twin spindle machining

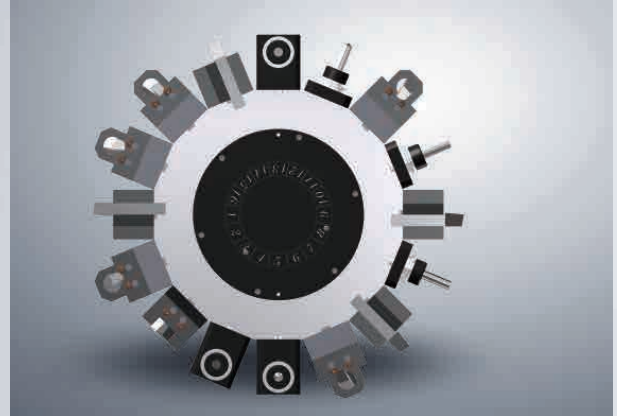

With the optional 16-station turret, maximum tool station capacity is up to 32 tools, which can easily fulfill various machining requirements.

2nd Spindle

- Chuck size : 6" (Big-bore) / 8" (Big-bore)
- Bar capacity : Ø 51 / Ø 65 mm
- Motor output : 11 / 15 kW (cont. / 30 min)
- High resolution Cs-axis close-loop control system

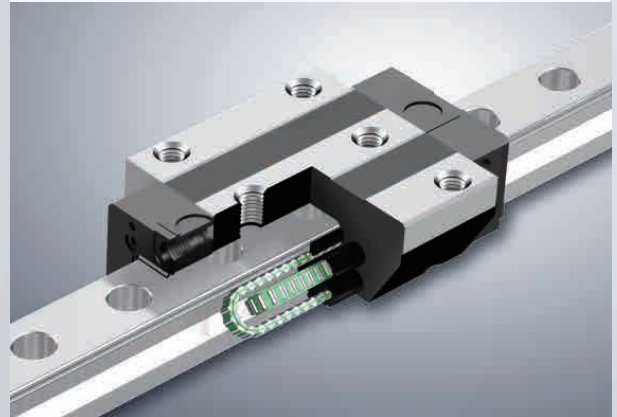

Roller type linear guide way provides rigidity for heavy cutting and speed for fast turning advantages.



The optional high resolution close-loop linear scale ensure optimal positioning and repeatability accuracy.

DIMENSIONS

12-Station Turret (For GTZ-2000)

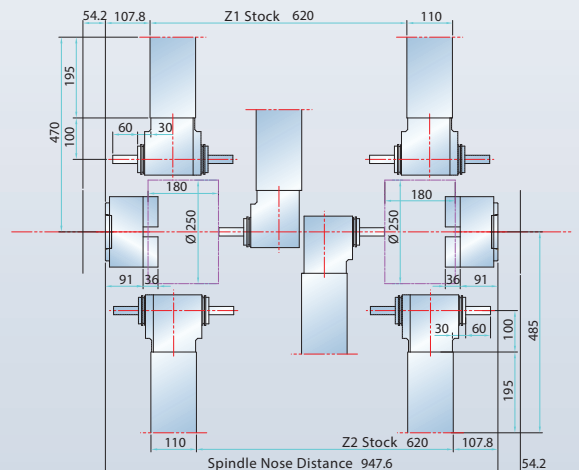
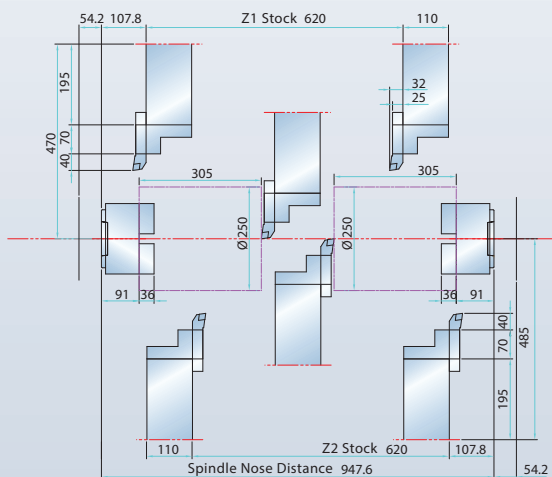
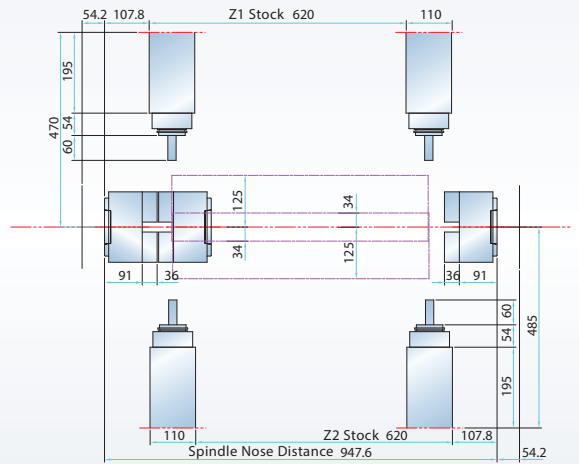
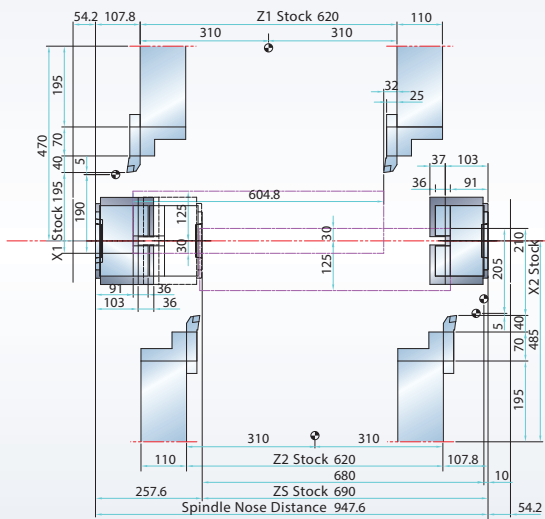
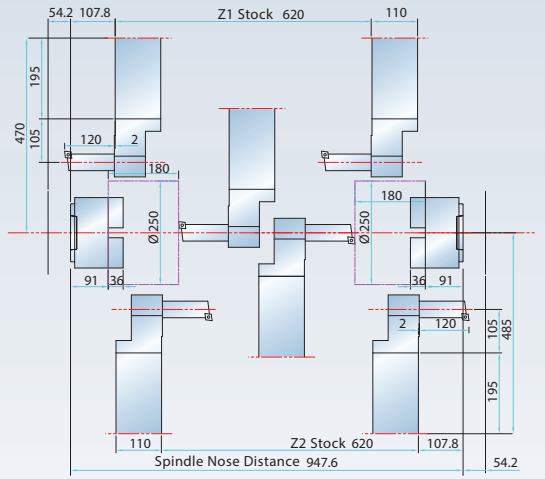
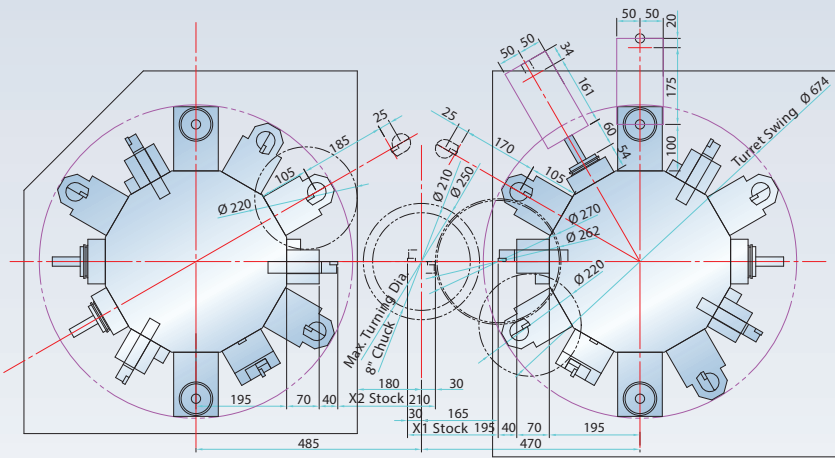

(Unit : mm)

Optional 16-Stations Turret (For GTZ-2000)

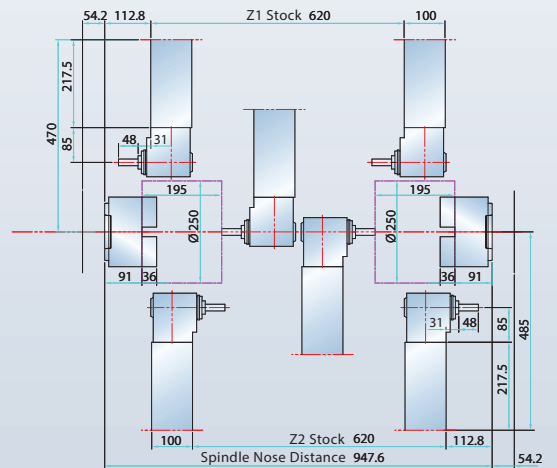
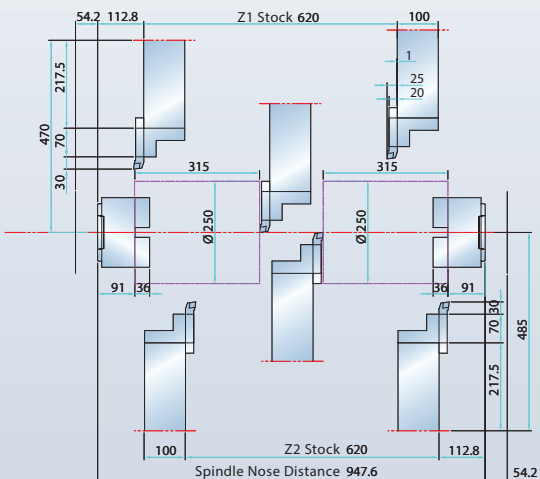
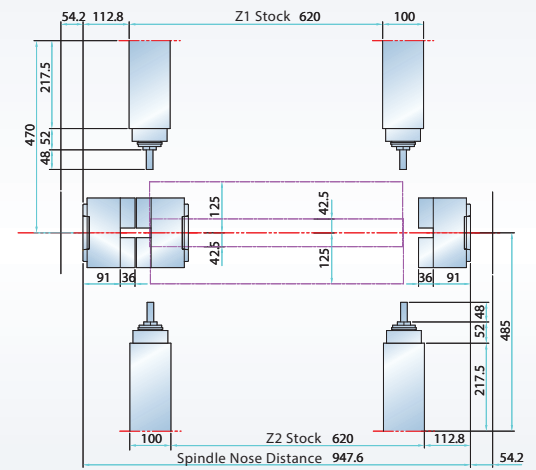
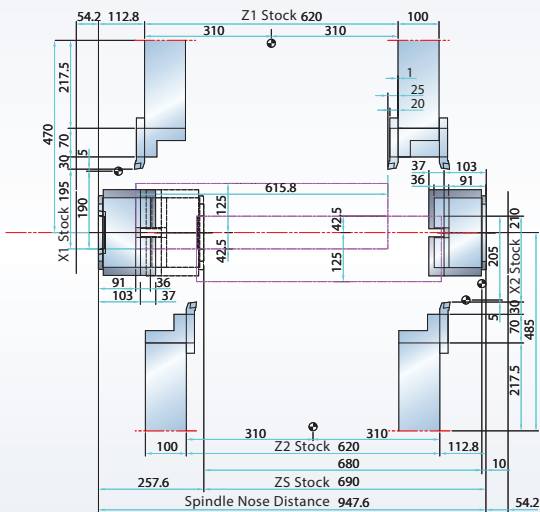
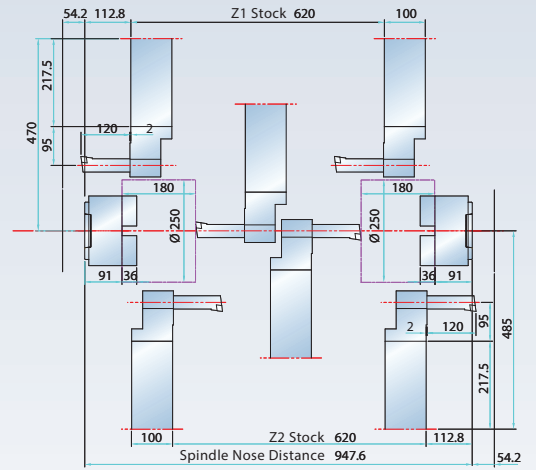
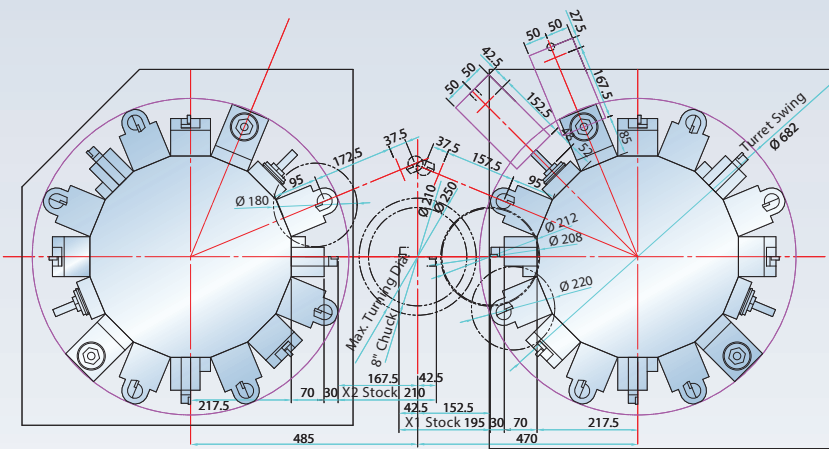

(Unit : mm)

MACHINE SPECIFICATIONS

CAPACITY	GTZ-2000	GTZ-2600
Max. swing diameter	Ø 270 mm (Ø 10.62")	
Max. turning diameter	Ø 250 mm (Ø 9.84")	
Max. turning length	604.8 / 615.8*1 mm (23.81" / 24.24"*1)	592.8 / 603.8*1 mm (23.33" / 23.77"*1)
Chuck size	6" (Big-bore)	8" (Big-bore)
Bar capacity	Ø 51 mm (Ø 2.00")	Ø 65 mm (Ø 2.55")
SPINDLE		
Hole through draw tube	Ø 52 mm (Ø 2.04")	Ø 65.5 mm (Ø 2.57")
Hole through spindle	Ø 66 mm (Ø 2.59")	Ø 76 mm (Ø 2.99")
Spindle bearing diameter	Ø 100 mm (Ø 3.93")	Ø 120 mm (Ø 4.72")
Hydraulic cylinder	8"	10"
Spindle nose	A2-5	A2-6
Spindle motor type	FANUC α P22 / 6000i (AC / Wide-Range)	
Motor output (Cont.)	11 kW (15 HP)	
Motor output (30 min.)	15 kW (20 HP)	
Motor full output speed	750 rpm	
Spindle drive system	Direct Belt Drive	
Spindle drive ratio	4 : 5	2 : 3
Spindle speed range	48 ~ 4,800 rpm	40 ~ 4,000 rpm
Spindle full output speed	600 rpm	500 rpm
Spindle torque (Cont.)	175 N-m (129 ft-lb)	210 N-m (155 ft-lb)
Spindle torque (30 min.)	239 N-m (176 ft-lb)	287 N-m (211 ft-lb)
C-AXIS (OPTIONAL)		
Drive type	Cs	
C-axis rapids	400 rpm	
X / Z AXES		
Max. X ₁ / X ₂ axes travel	195 / 210 mm (7.67" / 8.26")	
Max. Z ₁ / Z ₂ axes travel	620 / 620 mm (24.39" / 24.39")	
Max. Zs-axis travel	690 mm (27.16")	
X / Z axes rapids	24 m/min (944 IPM)	
Slide way type	Linear Guide Way	
Feed rates	1~ 4,800 mm/min (1 ~ 189 IPM)	
X / Z axes servo motor	AC 3.0 kW (4 HP)	
X / Z axes thrust	961 kgf (2,118 lbf)	
TURRET		
Station	12 + 12 [16 + 16 (Opt.)]	
Indexing drive	FANUC AC Servo motor	
Indexing speed	0.2 sec. Adjacent / 0.5 sec. 180° degree (Single step)	
Accuracy	Positioning : ± 0.00069° Repeatability : ± 0.00027°	
OD tool shank size	□ 1" (Opt. □ 3/4")	
ID tool shank size	Ø 1-1/2" (Opt. Ø 1-1/4")	

Specifications are subject to change without notice.

*1 For 16-station turret

LIVE TOOLING TURRET (OPTIONAL)	GTZ-2000	GTZ-2600
Stations / Live tooling stations	12 + 12 [16 + 16 (Opt.)]	
Indexing drive	FANUC AC Servo motor	
Index speed	0.2 sec. Adjacent / 0.5 sec. 180° degree (Single step)	
Accuracy	Positioning : $\pm 0.00069^\circ$ Repeatability : $\pm 0.00027^\circ$	
Live tooling drive motor	AC 3.7 / 5.5 kW (5 / 7.5 HP)	
Live tooling shank size	ER32 ($\varnothing 3/4"$) [Opt. ER25 ($\varnothing 5/8"$)]	
Live tooling RPM range	6,000 rpm	
Y-AXIS (OPTIONAL)		
Max. Y-axis travel	100 = ± 50 mm (3.93" = $\pm 1.96"$)	
Y-axis rapids	10 m/min (394 IPM)	
Slide way type	Linear Guide Way	
Feed rates	1~ 4,800 mm/min (1 ~ 189 IPM)	
Y-axis servo motor	AC 1.6 kW (2.0 HP)	
Y-axis thrust	640 kgf (1,410 lbf)	
UNLOADING SYSTEM (OPTIONAL)		
Max. work-piece diameter	$\varnothing 60$ mm ($\varnothing 2.36"$)	
Max. work-piece length	150 mm (5.90")	
Max. work-piece weight	3 kg (6.6 lb)	
GENERAL		
Positioning accuracy	± 0.005 mm ($\pm 0.00020"$)	
Repeatability	± 0.003 mm ($\pm 0.00012"$)	
CNC control	FANUC O_i - TF / FANUC 31 <i>i</i> (Opt.)	
Voltage / Power requirement	AC 200 / 220 + 10 % to -15 % 3 Phase / 60 kVA	
Hydraulic tank capacity	35 L (9 gal)	
Coolant tank capacity	380 L (100 gal)	
Coolant pump	0.7 kW (1 HP) / 5 Bar	
Machine weight	9,000 kg (19,842 lb)	
Dimensions (L x W x H)	4,445 x 2,555 x 2,360 mm (175" x 101" x 93")	

Specifications are subject to change without notice.

Machine Layout

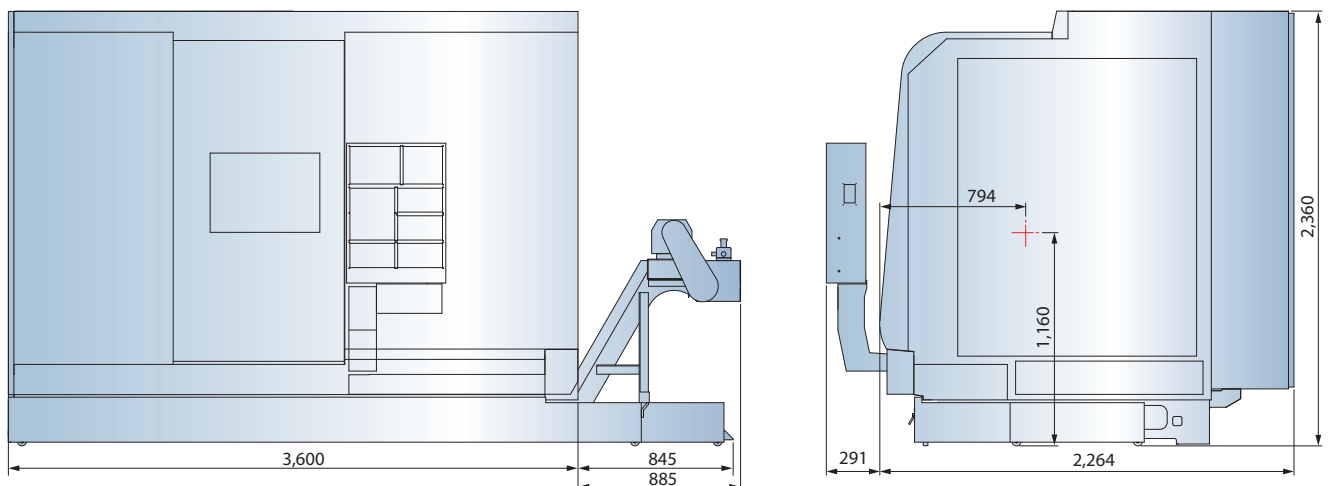

Unit : mm



YAMASEIKI.com

YAMA SEIKI USA, INC.

5788 Schaefer Ave., Chino, CA 91710

TEL : (888) 976-6789

(909) 628-5568

FAX : (909) 993-5378

E-mail : sales@yamaseiki.com