

GS-6000 SERIES

Heavy-duty CNC Turning Centers

www.YAMASEIKI.com



YAMA SEIKI[®]
TURNING CENTERS by **WOODWAY**[®]

MAXIMUM PERFORMANCE CNC TURNING CENTERS

With leading technologies and high quality components, the GS-6000 series maximum performance turning centers combine high rigidity box way bed with super large diameter servo indexing turret and 2-step gear spindle structure that provides great horse power, high speed indexing, and heavy-duty cutting capabilities. The GS-6000 series is available with optional L² model, with up to 3,300 mm (129.9") turning length and M model, with live tooling turret and C-axis, which enables higher cutting flexibility and multi-tasking power to meet most of today and tomorrow's turning applications demands.

- ▶ The first thing you'll notice inside the door of the GS-6000 series is the massive turret, which boasts a turret disk over 750 mm (29.5") in diameter. Blazing fast indexing times of 1 seconds from station to station and 2 seconds for stations at 180 degrees are achieved with servo indexing technology.
- ▶ Under the covers, you'll find a 45 degree true slant bed with super wide box ways and an enormous 2-speed head stock driven by a 37 kW (50 HP) (30 min.) FANUC motor.
- ▶ Axes rapids are 20 m/min (788 IPM) on X and 24 m/min (945 IPM) on Z, which are 50 ~ 100 % faster than the competitors.
- ▶ Utilizing the most advanced industrial design, the fully enclosed protection covers isolates cutting chips and coolant inside the machine.



- ▶ Available live tooling and C-axis capabilities in the GS-6000 series allows the machine to perform multiple tasks on a work-piece, such as turning, milling, drilling, and tapping. This decreases manpower and cycle time as well as eliminates the accuracy lost when a part is moved from machine to machine. (More on P9.)

- ▶ 3 bed lengths and 3 spindle sizes offer a total of 9 basic model configurations.

SERIES		GS-6000 SERIES	GS-6600 SERIES		GS-6800 SERIES
Chuck Size		Ø 15" (18")	Ø 20"	Ø 22" *1	Ø 24" *1
Bar Capacity		Ø 115 mm (4.52")	Ø 180 mm (7.08")	Ø 205 mm (8.07")	Ø 260 mm (10.24")
Turning Length	950 mm (37.4")	GS-6000 / M	GS-6600 / M		GS-6800 / M
	1,980 mm (77.95")	GS-6000L / LM	GS-6600L / LM		GS-6800L / LM
	3,300 mm (129.9")	GS-6000L ² / L ² M	GS-6600L ² / L ² M		GS-6800L ² / L ² M

「M」 model for optional live tooling turret function. *1 Optional Air Chuck



(GS-6000L² model shown with optional accessories)

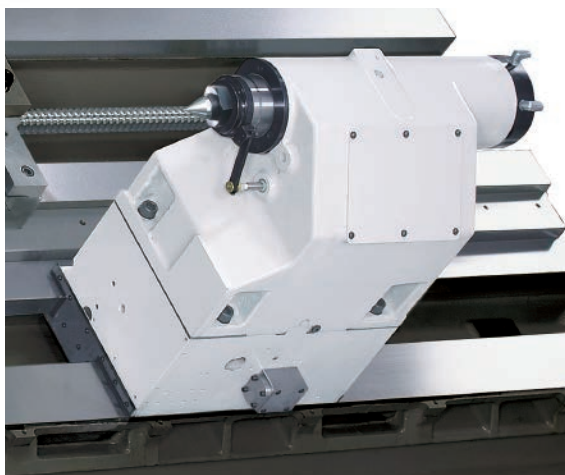

- ▶ Positioning of the programmable base tailstock has been simplified through use of custom software interface. The Z-axis carriage automatically locks on to the base of the tailstock and drags it to the desired position.
- ▶ The built-in bearing quill provides greater rigidity for heavyloads. The extension and retraction of the quill is programmable and thrust pressure adjustable.

SUPER HEAVY-DUTY CONSTRUCTION

- ▶ Major structural components have been combined into one solid platform. The low center of gravity 45° slant bed design provides the most rigid foundation possible for the headstock, turret, and tailstock.
- ▶ By using Finite Element Methods (FEM), optimally reinforced ribbings are directly cast into the one-piece bed structure. Mechanical rigidity has been increased by more than 40 % when compared to conventional designs. The GS-6000 series is capable of performing super heavy-duty turning and maintain long-term super high precision accuracy. More rigidity also means extended tool life.
- ▶ Built to endure years and years of rigorous high production turning, the heavily ribbed, one-piece thermally balanced bed and casting components are of FC35-MEEHANITE casting (industry standard is FC25~30). FC35 grade cast iron is capable of withstanding much greater stress without deformation and provides maximum vibration damping, which results in a machine that will outlast and outperform the competition.

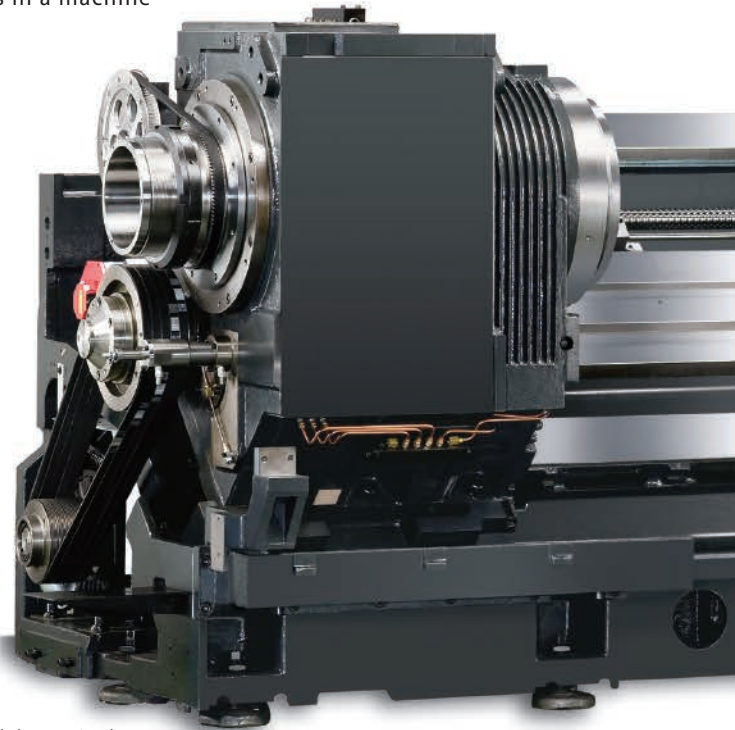

- ▶ The 2-step super heavy-duty gear head incorporates advanced mechanical designs. Mated with a 37 kW (50 HP) (30 min.) motor to provide tremendous amount of low-end torque to handle heavy material removal on large diameter parts.

- ▶ Extra wide hardened and ground box ways are directly formed into the machine bed and saddle during the casting process. They are precision machined and widely spaced for maximum strength. The box way design also provides the rigidity needed for heavy-duty and interrupted turning applications.

- ▶ C3 class hardened and precision ground ball screws ensure the highest accuracy and durability possible. Plus, pretension on all axes minimizes thermal distortion.

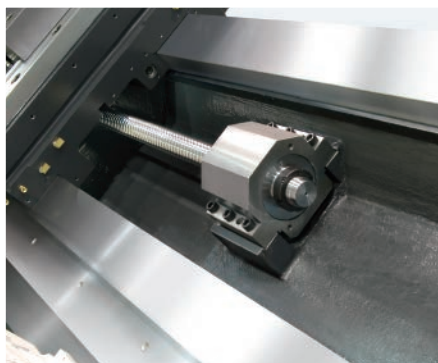

- ▶ All spindle and servo motors, including drives, are FANUC αi series components to ensure peak machining performance and accuracy.

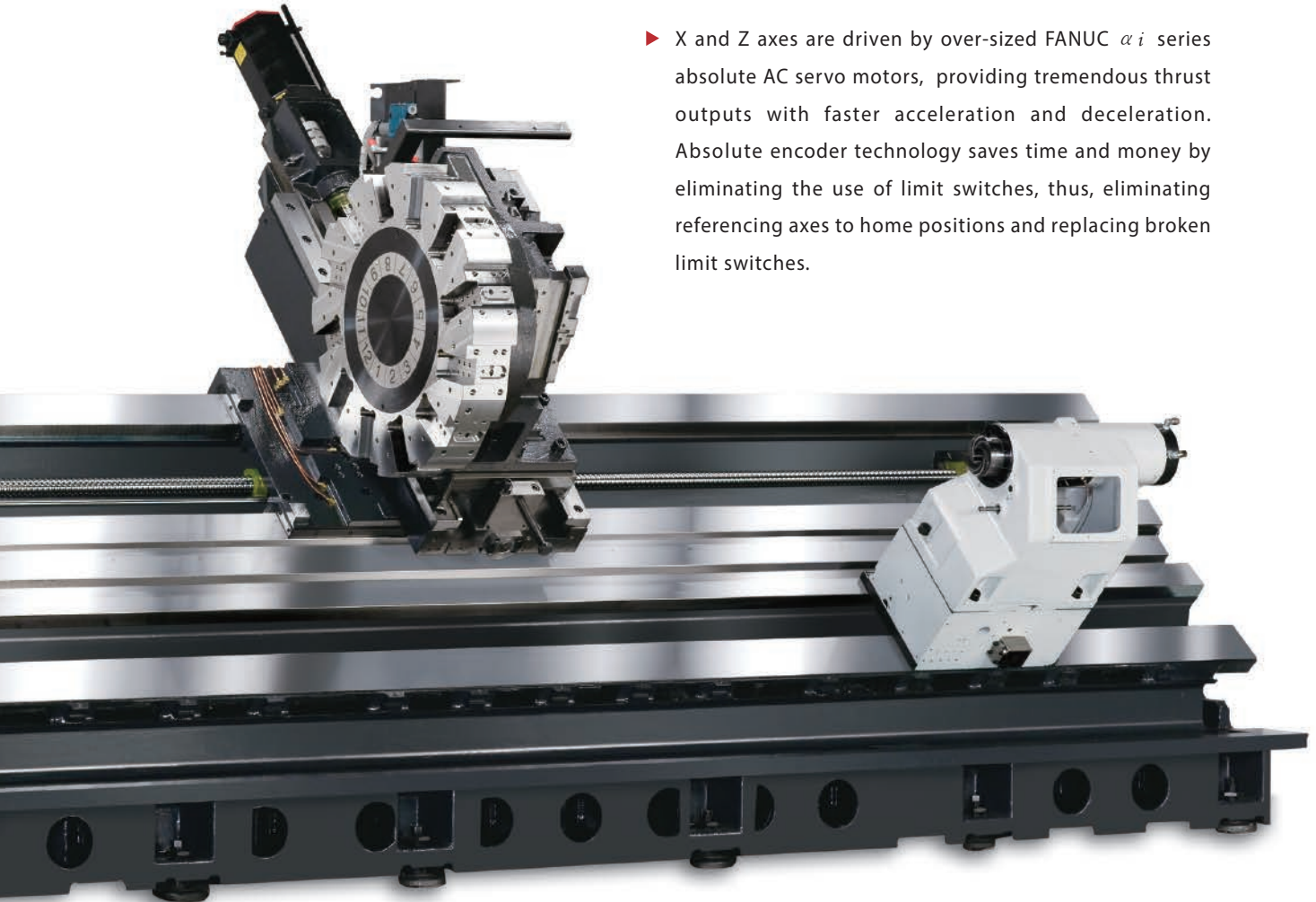

(Casting structure of GS-6000L² model shown)

- ▶ X and Z axes are driven by over-sized FANUC αi series absolute AC servo motors, providing tremendous thrust outputs with faster acceleration and deceleration. Absolute encoder technology saves time and money by eliminating the use of limit switches, thus, eliminating referencing axes to home positions and replacing broken limit switches.



- ▶ The L² series Z-axis equipped with independent supporting mechanism prevents long sized ball screws from deforming and ensures excellent performance for the axial feed and turning accuracy.

- ▶ Both gears and bearings are lubricated and cooled by an oil mist system, which evenly and efficiently lubricates the components. This system is much more advanced compared to the traditional oil bath system by eliminating the chance of oil contaminating the bearings.



ULTIMATE TURNING POWER

- ▶ P4 grade (Class 7) super high precision bearings are directly assembled for maximum level of support and precision. Bearing configuration is designed for heavy-duty cutting with ultra smooth performance and long term durability with higher level of accuracy.
- ▶ With over 2,048 N-m (1,510 lb-ft) of torque available on low speed of the 2-step gear head, turning tough material with big diameter is now a simple task.

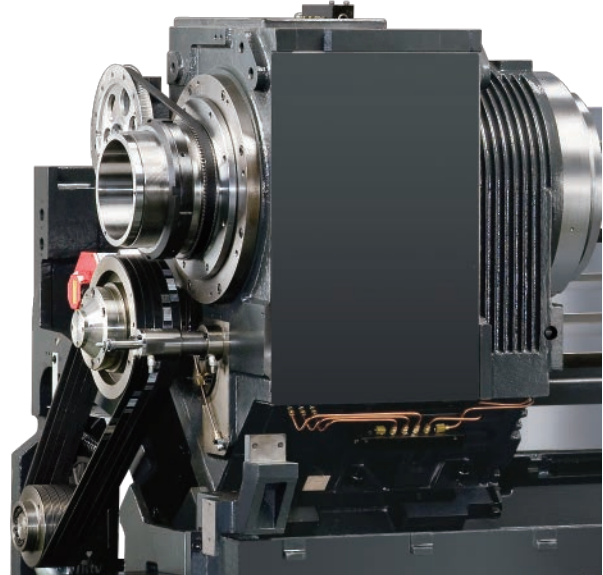
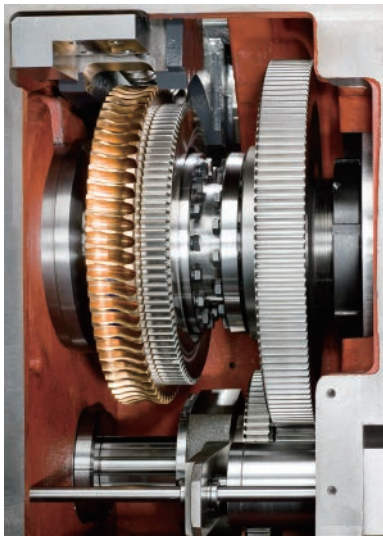

- ▶ Working with the live tooling turret, the Cf-axis and disk brake system enables the machine to perform multiple tasks, such as drilling, tapping and milling operations including cylindrical and polar coordinate interpolations, resembling a 4th-axis rotary table on a machining center.

Spindle Output

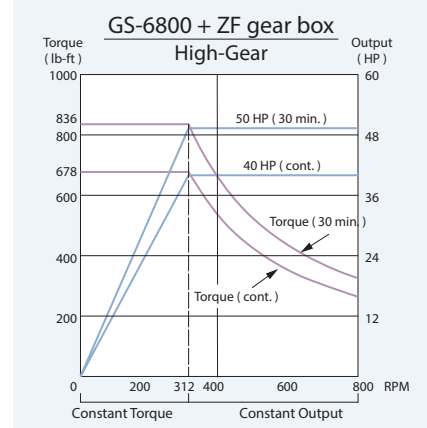
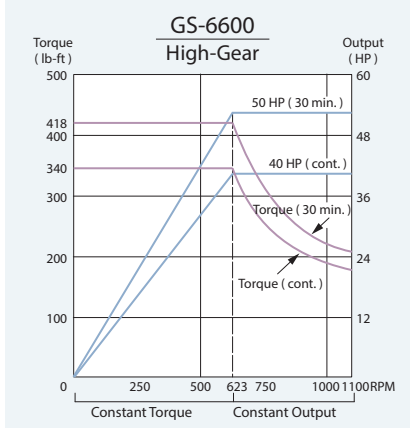
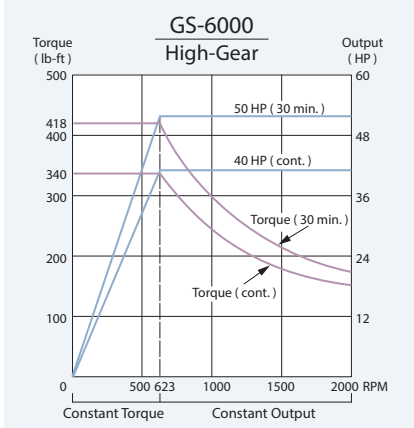
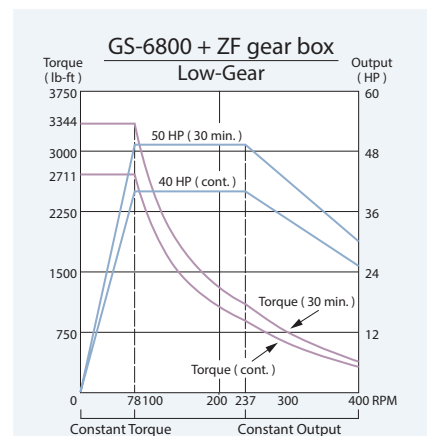
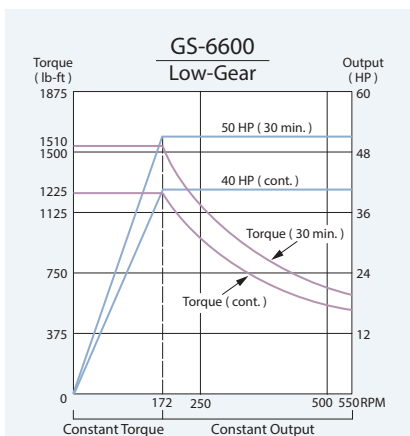
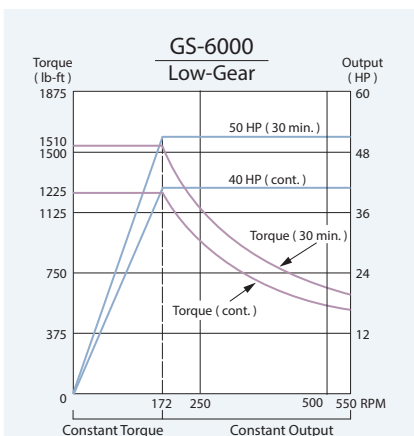

- ▶ The GS-6000 series is standard with a 2-step gear box. Optional oil bath German made ZF 3-step gear box is also available providing maximum torque up to 4,912 N-m (3,625 lb-ft).

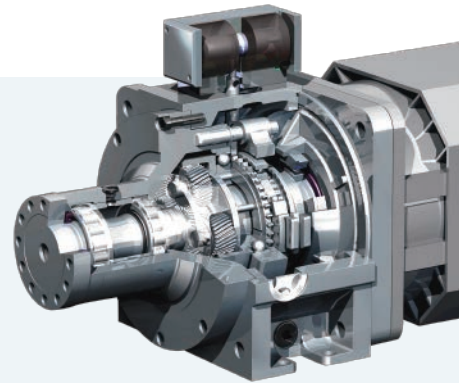

Optional ZF Gear Box Output

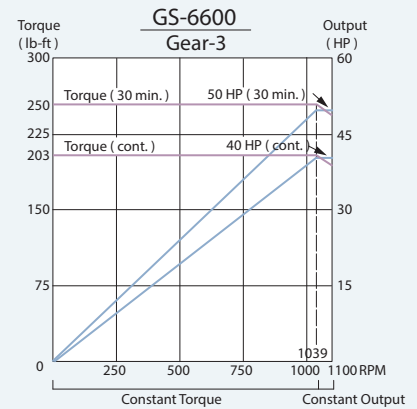
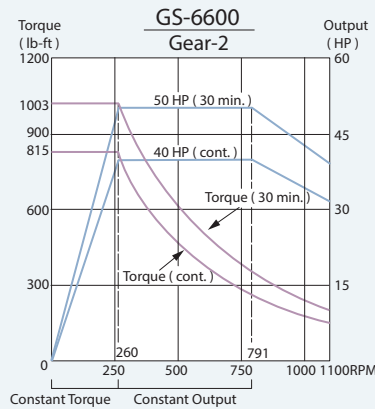
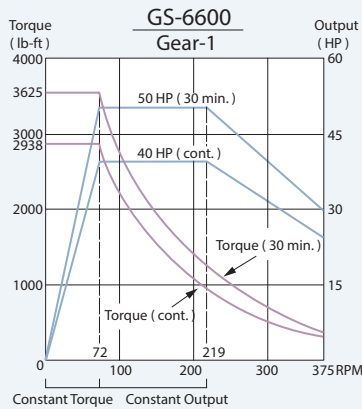
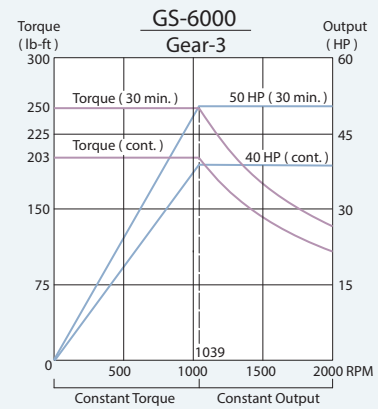
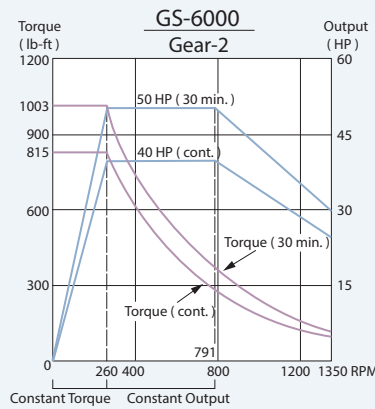
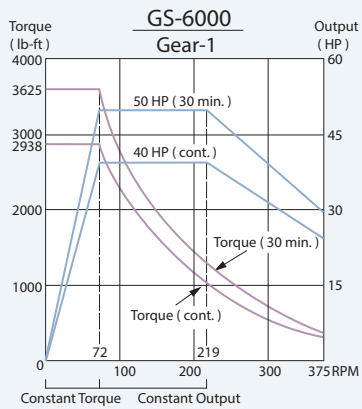

Front + Rear Chuck

By installing air or manual chucks on both the front and rear of the spindle, it becomes possible to machine the ends of long work-pieces. This configuration is especially useful in threading pipes.

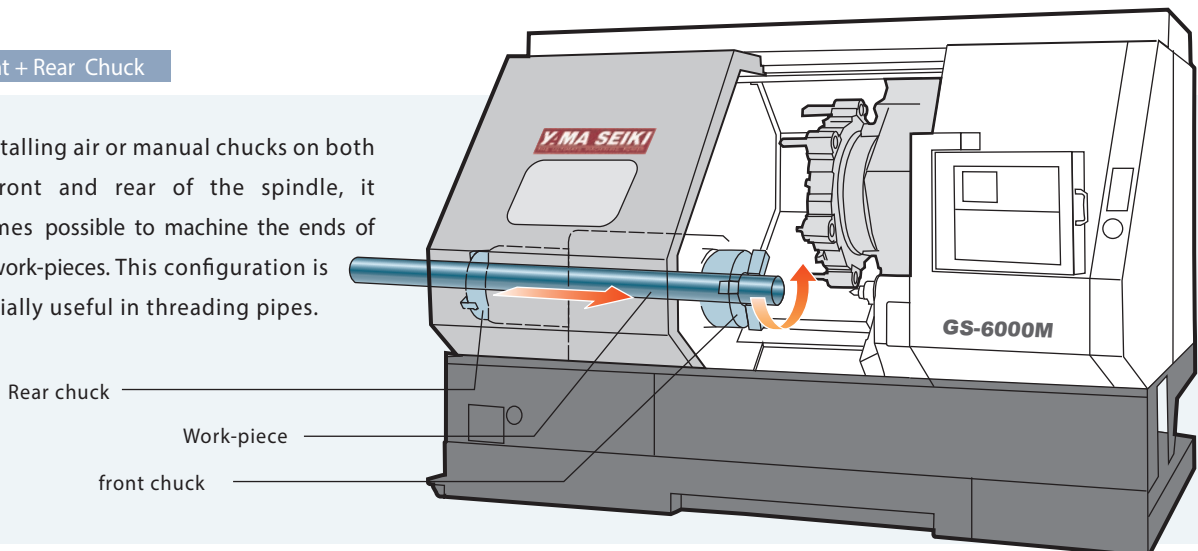

ADVANCED TURRET TECHNOLOGY

- ▶ While competitors are cutting cost by using straight couplings on their turrets, we insist on using the finest curvic couplings available. The curvature of the curvic teeth provides a very unique self-centering feature and wider uniform tooth contact throughout all the teeth, therefore, achieving very high accuracy and rigidity. The curvic teeth are hardened to HRC 58, which ensures the coupling retains its high accuracy characteristics over long periods of use.
- ▶ \varnothing 450 mm (17.7") diameter super high precision curvic couplings accurately position the turret disk (± 2 sec. of arc) and 12,000 Kg (26,400 lb) of clamping force ensures abundant turret rigidity for all cutting conditions.
- ▶ The 12-station heavy-duty servo indexing turret achieves 1 second indexing times for adjacent stations and 2 second times for stations at the opposite end of the disk turret. Index movements are continuous without pauses, and are capable of turning \varnothing 375 mm (14.7") diameter work-pieces without interference when using boring tools. The optional 8-station turret clears up to \varnothing 540 mm (21.2") diameter.

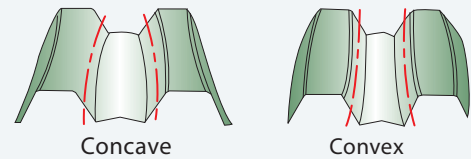
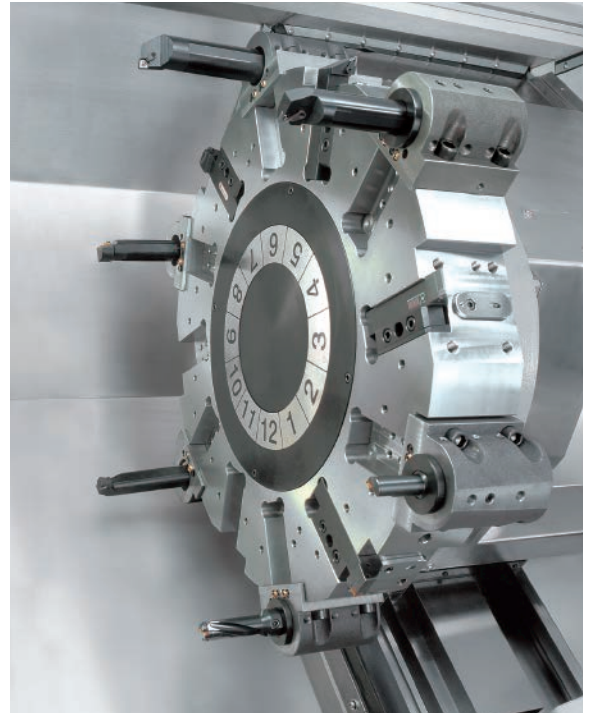

Curvic Coupling

[Standard 12-Stations Turret]

Tooling System

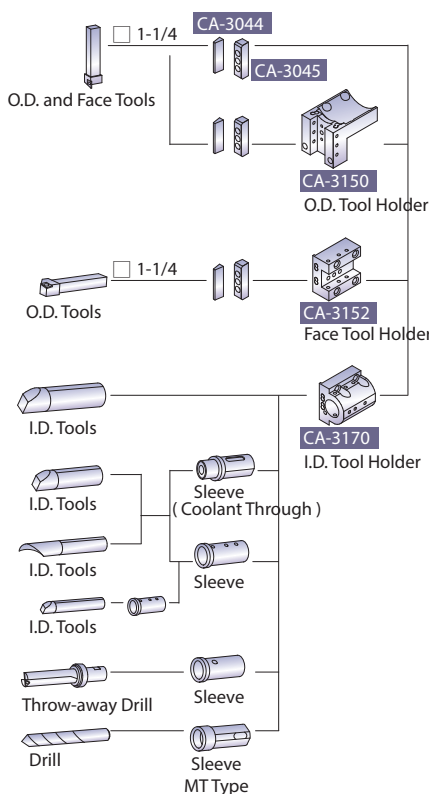

Interference Diagram

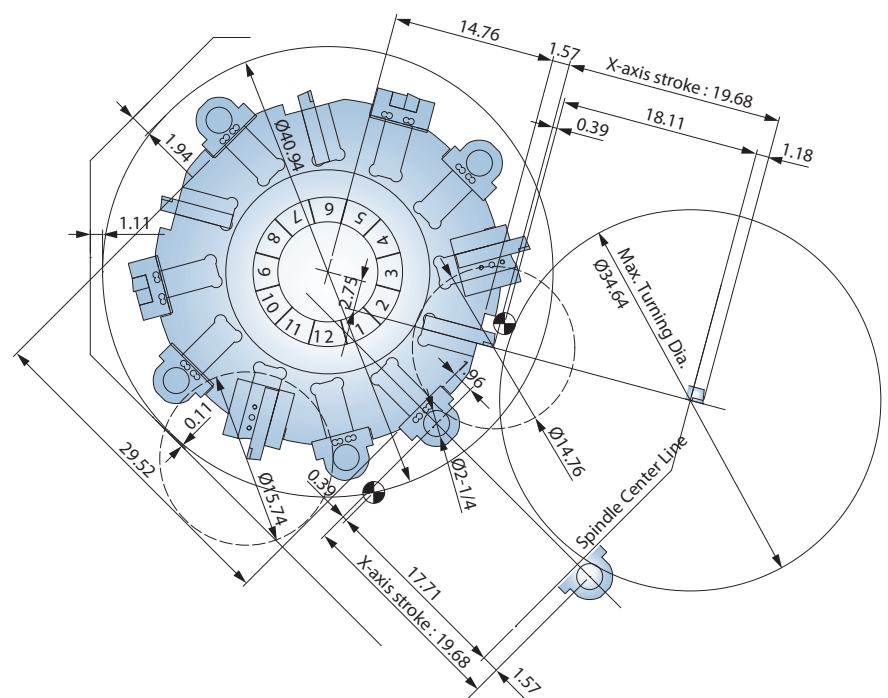

Work Range

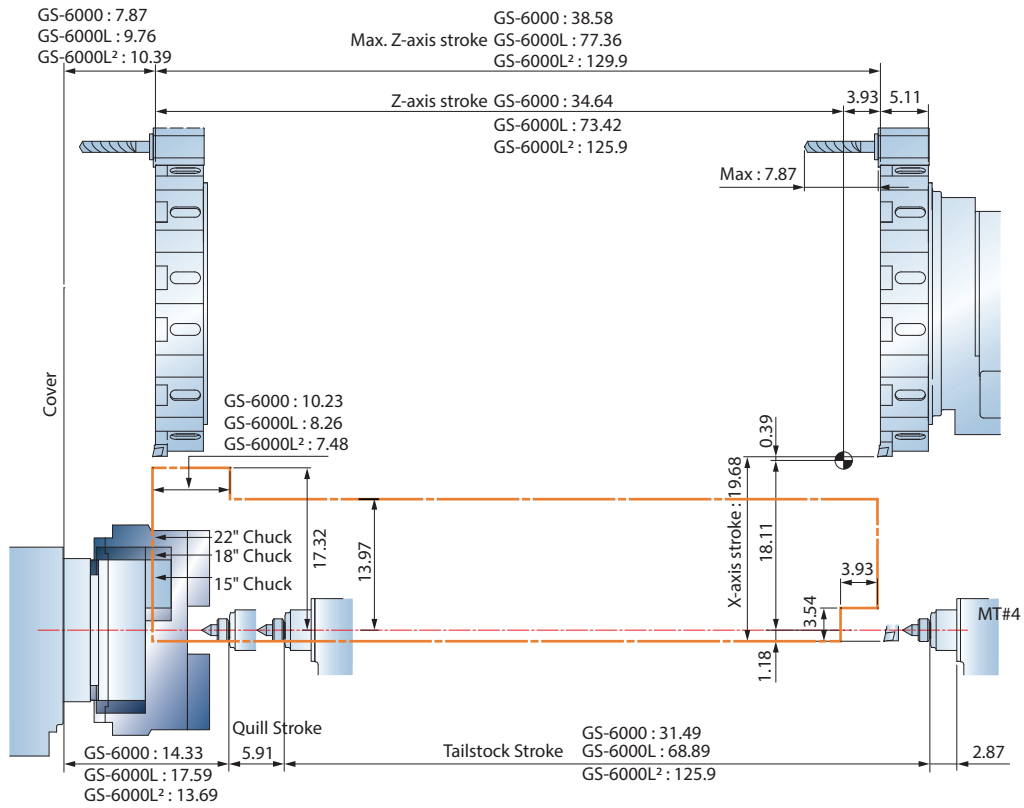

[Optional 8-Stations Turret]

Tooling System

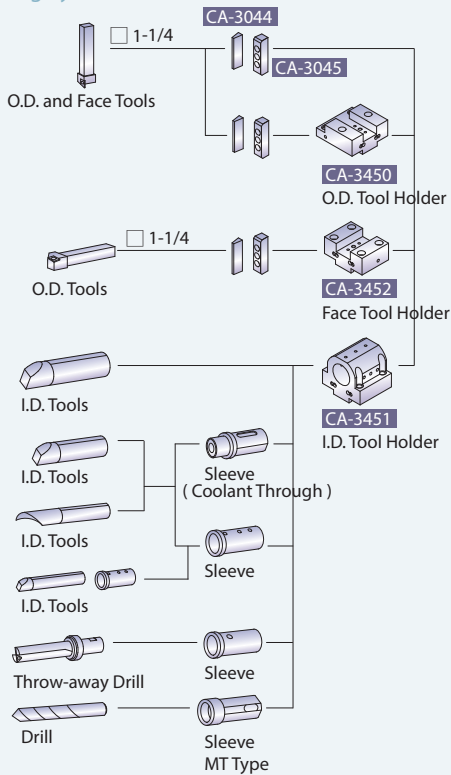

Interference Diagram

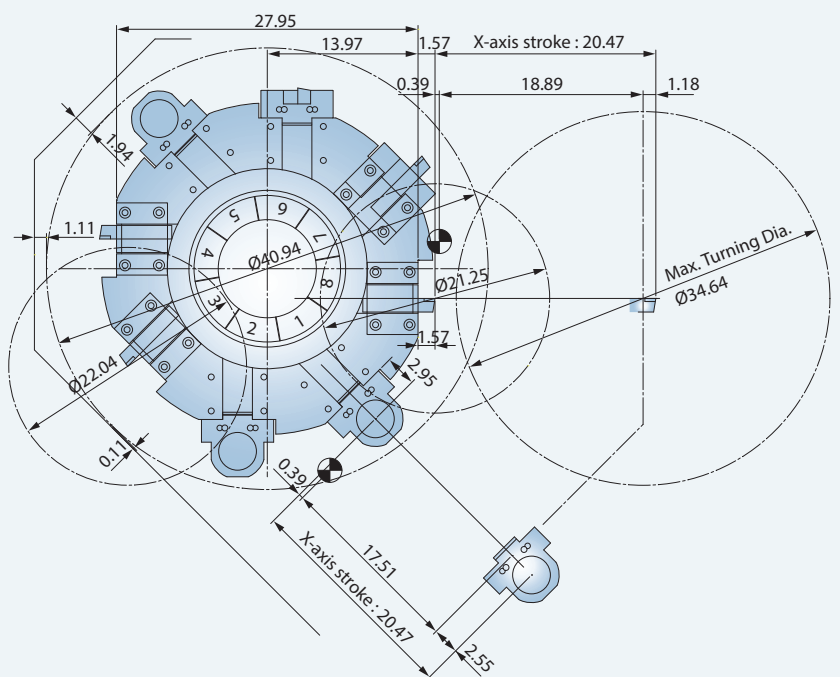

*1 Work range with 8-Stations Turret, please contact YAMA SEIKI.

LIVE TOOLING TURRETS

- ▶ Live tooling and C-axis control capabilities on the GS-6000 series allows the machine to perform multiple tasks on a work-piece, such as turning, milling, drilling and tapping. It decreases manpower and cycle time, as well as eliminates the loss of accuracy that would occur when a part is moved from machine to machine.
- ▶ More powerful than a standard 50-taper machining center, the GS-6000 series live tooling turret is driven by 9 kW (12 HP) (30 min.) AC double wound high torque spindle motor to provide ample power, now, even the toughest jobs may be tackled without a sweat. (Please see page 12 for motor specification)
- ▶ The 12-station YAMA SEIKI live tooling turret offers 12 stations available for live tooling; live tools rotate in working position only to reduce power loss and heat.
- ▶ YAMA SEIKI live tooling turret utilizes advanced servo indexing technology to achieve 1 seconds indexing time for adjacent stations and 2 seconds for stations at the opposite end of the disk.

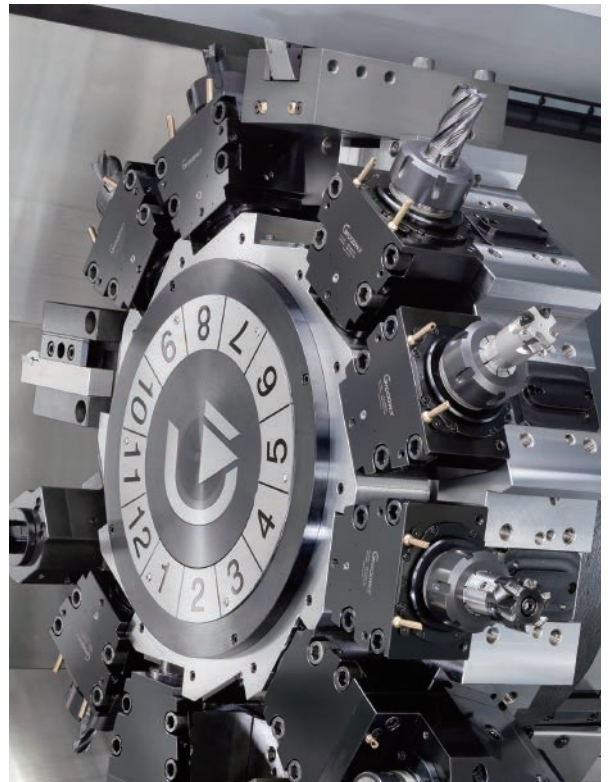

ULTIMATE C-AXIS SPINDLE

- ▶ The Cf-axis and disk brake system available on the GS-6000 series provide the most rigid and powerful type of C-axis on the market today. In Cf-axis mode, a servo motor is engaged and drives the rotation of the spindle; engaging time is approximately 1 second.

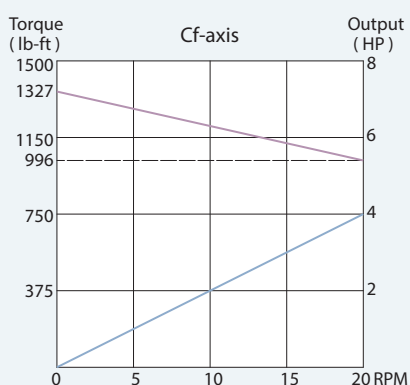

- ▶ Working with the live tooling turret, the Cf-axis and disk brake system enables the machine to perform multiple tasks, such as drilling, tapping, and milling operations, including cylindrical and polar coordinate interpolations, resembling a 4th-axis rotary table on a machining center.
- ▶ With the FANUC servo motor generating an ultra high resolution of 1,000,000 pulses per spindle rotation and 1,800 N-m (1,327 lb-ft) of spindle torque (Cont.), machined surface finishes are much superior than Cs-axis (driven by spindle motor) equipped machines. Plus, dynamic accuracy is within $\pm 0.02^\circ$ even under heavy cutting loads.

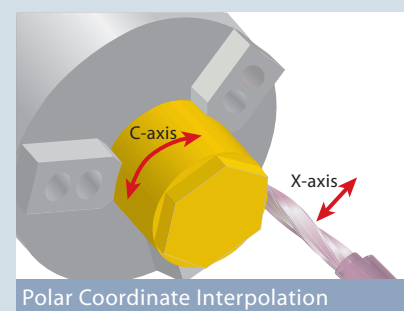
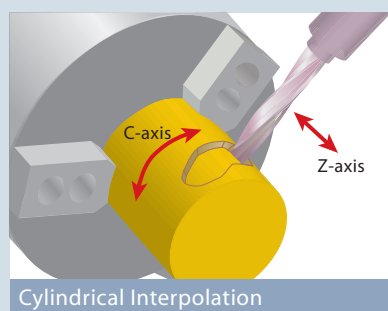
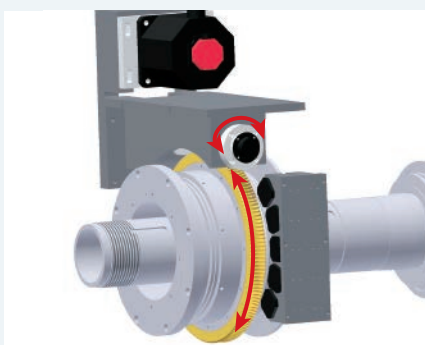

[Optional 12-Stations Live Tooling Turret]

Work Range

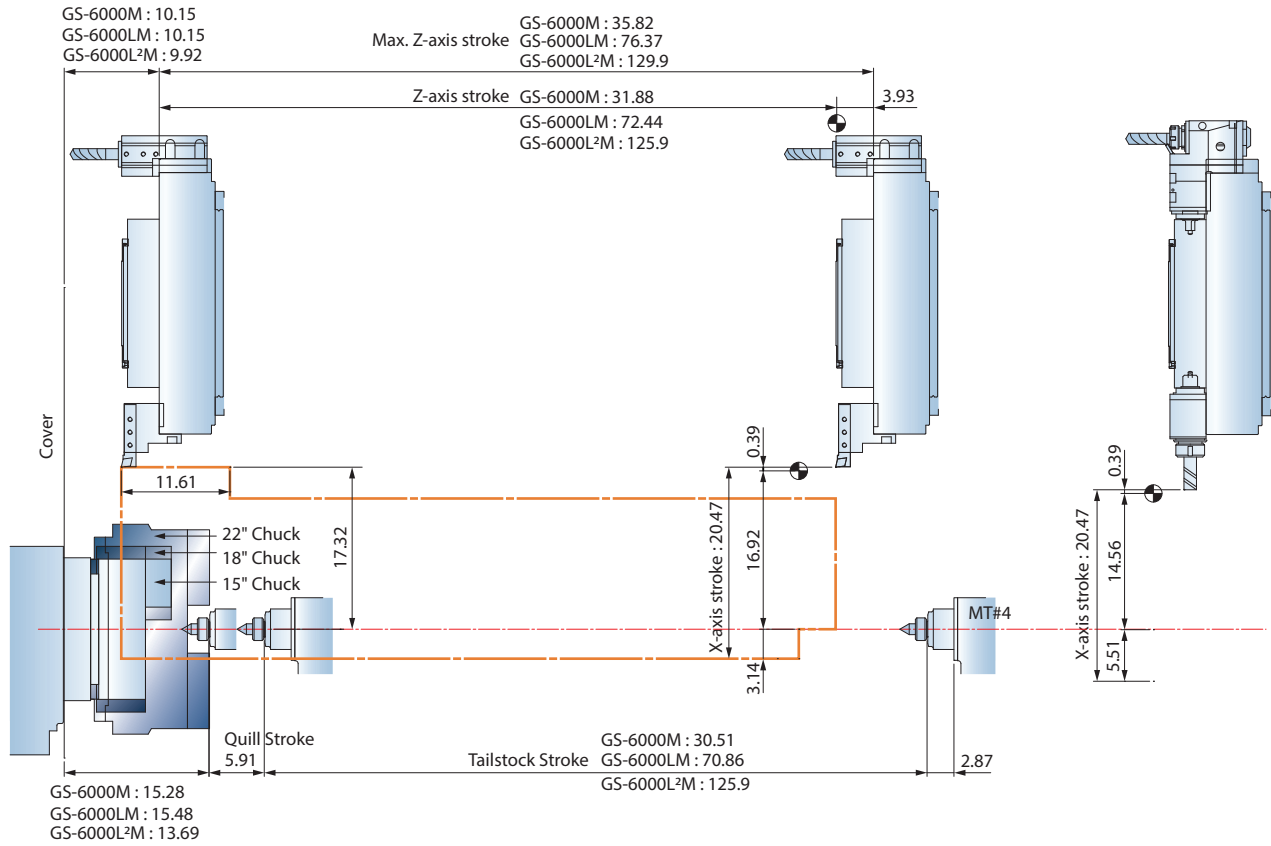

Tooling System

Interference Diagram

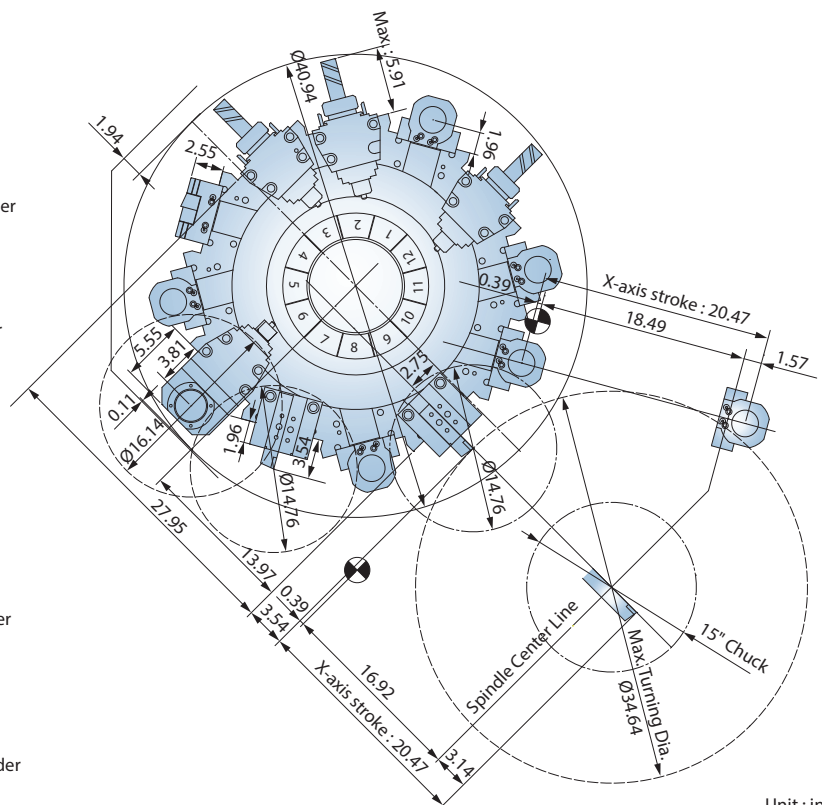
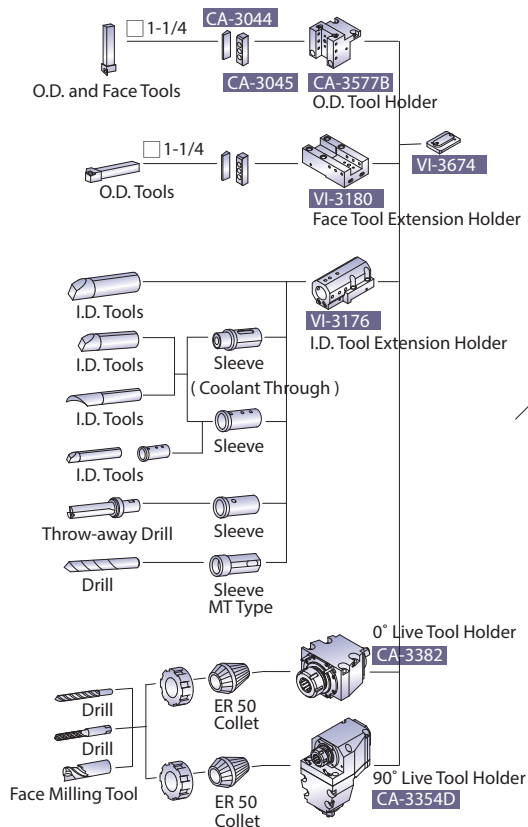

MACHINING PERFORMANCE



OD Heavy Cutting Example

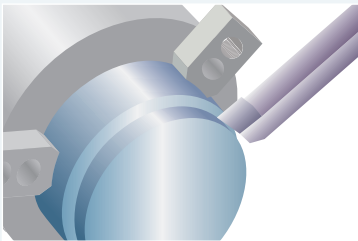

Tools	OD Before Cut	OD After Cut	Depth of Cut	Spindle Speed	F / Rev.	Spindle Load	Z-axis Load
□ 32 mm (1-1/4")	Ø 215 mm (8.46")	Ø 195 mm (7.67")	10 mm (0.39")	195 rpm	0.8 mm (0.031")	97 %	60 %

Raw Material : S45C Model : GS-6000M

Drill Example

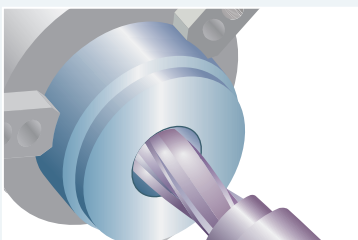

Tools	ID Before Cut	ID After Cut	Tap Diameter	Spindle Speed	F / Rev.	Spindle Load	Z-axis Load
Ø 58 mm (2.28")	-	-	-	878 rpm	0.3 mm (0.0118")	123 %	110 %

Raw Material : S45C Model : GS-6000M

Machining Capability

	Tools (mm)	Spindle Speed (rpm)	Feed rate (mm / min)	Cutting Speed (m / min)	Cutting Depth (mm)
Drill	Ø 40 (1.57") HSS	200	48 (1.9 IPM)	25 (984 IPM)	N/A
End mill	Ø 32 (1.25") HSS 4-flute Rough End mill	375	120 (4.7 IPM)	30 (1,180 IPM)	25 (0.98")
Tapping	M24 * P3.0	106	318 (12.5 IPM)	8 (314 IPM)	30 (1.18")

Raw Material : S45C Model : GS-6000M

Live Tooling Turret

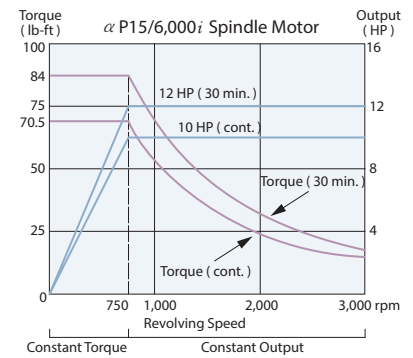

Specification of Live Tooling Turret

Drive Motor Power (cont.)	Drive Motor Power (30 min.)	Drive Motor	Max. tapping Capacity	Max. Milling Capacity	Gear Ratio
7.5 kW (10 HP)	9 kW (12 HP)	FANUC α P15 / 6000i	M24	Ø 40 mm (1.57")	1 : 1

YAMA SEIKI Multi-tasking machine can perform the functions below in one setup :

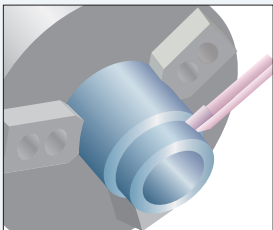

Turning

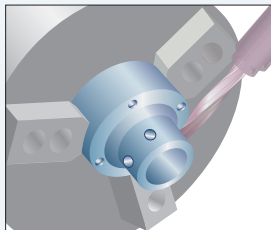

Side Drilling & Tapping

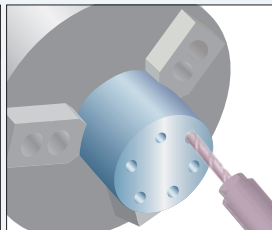

Face Drilling & Tapping

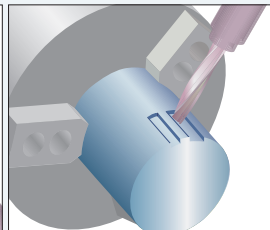

Keyway Milling

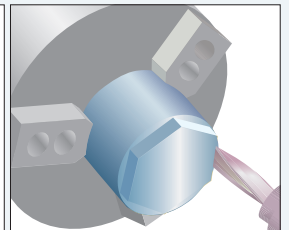

Contour Milling

Sample Work-pieces



FEATURES

【 Standard Features 】



Chip Conveyor

- ▶ The standard chip conveyor features adjustable timers that allow the operator to set operation intervals according to the amount of chips generated by the machine. Thus, reducing coolant loss to minimum.

Separate Coolant Tank



Tri-color status light



【 Optional Features 】

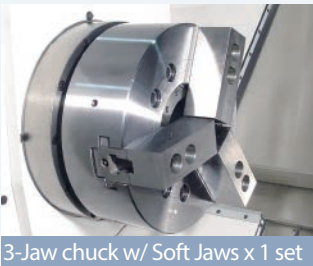

3-Jaw chuck w/ Soft Jaws x 1 set



Air Chuck

- ▶ The air chuck can work with soft or thin materials to prevent from deforming rather than using a hydraulic chuck.

Steady Rest (Apply for Long Work-piece)

- ▶ The manual steady rest is adjusted manually which increases accuracy and requires less space than hydraulic steady rests.



Manual Steady Rest



Hydraulic Steady Rest

- ▶ The automatic steady rest is controlled by a program which increases working efficiency.

LOAD MONITOR SETTING		1/4		UNIT:%	
code	AXIS	INITIAL	CURRENT	LIFE	BREAK
1	SP	0	0	0	0
	Z	0	0	0	0
2	SP	0	0	0	0
	Z	0	0	0	0
3	SP	0	0	0	0
	Z	0	0	0	0

NUM-

{ TECH } { MONI } { CAN } { } { }

Load Monitoring

- ▶ The load monitoring function is used to detect abnormal load of tools by monitoring the variation in spindle motor and servo motor loads during the cutting process. When abnormal loads are detected, the machine will stop at program end (M30) or immediately (feed hold status) according to tool life value or tool break value respectively.



Oil Skimmer

- ▶ The optional oil skimmer removes lubrication oil from the coolant tank, thus, keeping the coolant fresh and minimizes manual cleaning.

Tool Setter

- ▶ The optional RENISHAW HPR tool presetter simplifies machining setup.



S: Standard O: Option
 -: Not Available C: Contact YAMA SEIKI

		GS-6000	GS-6600	GS-6800
SPINDLE				
Main spindle configuration	2-Speed Gear	S	S	S
Rigid tapping & spindle orientation		S	S	S
Main spindle disk brake		O	O	O
Cs-axis & disk brake for main spindle*1		O	O	O
WORK HOLDING				
Hydraulic hollow cylinder for chuck	115 mm ID	S	-	-
	180 mm ID	-	O	-
	205 mm ID	-	O	-
	260 mm ID	-	-	O
Hollow 3-jaws chuck & 1 set soft jaws	15"	S	-	-
	18"	O	-	-
	20" (180 mm ID)	-	O	-
	21"	-	O	-
	24"	-	O	O
	Air Chuck	O	O	O
Hard jaws		O	O	O
Special work holding chuck		C	C	C
In spindle work stopper		O	O	O
Spindle liner (guide bushing)		O	O	O
Foot switch for chuck operation		S	S	S
Programmable base & quill hydraulic tailstock		S	S	S
MT#4 dead center quill		S	S	S
MT#5 live center quill		O	O	O
MT#5 dead center quill		O	O	O
MT#6 live center quill		O	O	O
Foot switch for tailstock operation		O	O	O
Manual steady rest		O	O	O
Self-centering hydraulic steady rest		O	O	O
Foot switch for steady rest operation		O	O	O
Two-stage programmable pressure	Chuck clamping	O	O	O
	Tailstock thrust	O	O	O
TURRET				
8-station turret		O	O	O
12-station turret		S	S	S
12-station live tooling turret		O	O	O
Tool holder & sleeve package		S	S	S
Live tooling tool holders (0° x 2 , 90° x 2)*1		O	O	O
MEASUREMENT				
Renishaw HPRA tool presetter	Removable	O	O	O
COOLANT				
Coolant pump	100 PSI	S	S	S
	300 PSI	O	O	O
High-pressure coolant system	1,000 PSI	O	O	O
Roll-out coolant tank		S	S	S
Oil skimmer		O	O	O
Coolant flow switch		O	O	O
Coolant level switch		O	O	O
Coolant intercooler system		O	O	O
CHIP DISPOSAL				
Chip conveyor with auto timer	Right discharge	S	S	S
	Rear discharge	C	C	C
Chip cart with coolant drain		O	O	O
Chuck air blow		O	O	O
Tailstock air blow		O	O	O
Coolant gun		O	O	O
Oil mist collector		O	O	O
AUTOMATIC OPERATION SUPPORT				
Bar feeder		O	O	O
Bar feeder interface		O	O	O
Gantry-type loader / unloader		O	O	O
Auto door		O	O	O
External M-code output	4 sets (8)	O	O	O
	8 sets (16)	O	O	O

Specifications are subject to change without notice.

Above standard & optional features also apply to L models.

*1 Standard on M (live tooling) models.

*2 10.4" color LCD option needed.

*3 The milling axis is with servo motor which is available when equipped with live tooling turret

SAFETY

		GS-6000	GS-6600	GS-6800
Fully enclosed guarding		S	S	S
Door interlock (incl. Mechanical lock)		S	S	S
Impact resistant viewing window		S	S	S
Proximity switch for tailstock quill position confirmation		S	S	S
Proximity switches for chuck clamp / unclamp confirmation		S	S	S
Chuck cylinder check valve		S	S	S
Low hydraulic pressure detection switch		S	S	S
Over travel (soft limit)		S	S	S
Load monitoring function		S	S	S

OTHERS

		GS-6000	GS-6600	GS-6800
Tri-color machine status light tower		S	S	S
Work light		S	S	S
External work light		O	O	O
Electrical cabinet	Heat exchanger	S	S	S
	A/C cooling system	O	O	O
Complete hydraulic system		S	S	S
Advanced auto lubrication system		S	S	S
Foundation leveling & maintenance tool kit		S	S	S
Emergency maintenance electrical part package		S	S	S
Operation & maintenance manuals		S	S	S

CONTROL

		GS-6000	GS-6600	GS-6800
FANUC Oi-TD		S	S	S
FANUC 31i		O	O	O

FANUC CONTROL FUNCTIONS

		Oi-TD	31i
PMC system	Oi-TD PMC : 25n sec/step	S	-
	31i PMC : 25n sec/step	-	S
Display	8.4" color LCD	S	-
	10.4" color LCD	O	S
Graphic function	Standard	S	-
	Dynamic	O	S
Full keypad	Small - 44 keys	S	-
	Large - 56 keys	O*2	S
Part program storage length	512 K byte	S	-
	1M byte	-	S
	2M byte	-	O
	4M byte	-	O
	8M byte	-	O
Registerable programs	400	S	-
	1,000	-	S
	4,000	-	O
	64	S	-
Tool offset pairs	99	O	S
	400	-	O
	499	-	O
	999	-	O
	2000	-	O
Servo control	HRV2 (3)	S	S
Conversational programming	Manual Guide Oi	S	-
	Manual Guide i	O*2	S
Servo motors	α i	S	S
Spindle motors	α i	S	S
Tool Life Management		S	S
Tool Nose Radius Compensation		S	S
Background editing		S	O
Variable Lead Thread Cutting		S	S
Polygon Turning		S	S*3
Unexpected disturbance torque detection function		S	S
Polar coordinate & cylindrical interpolation		-	O
Multiple Threading		S	S
Run hour & parts counter		S	S
Auto power off function		S	S
Custom macro B		S	S
RS-232 port		S	S
Memory card input / output		S	S
Ethernet		S	S
Fast ethernet		O	O

GENERAL DIMENSION

Floor Space

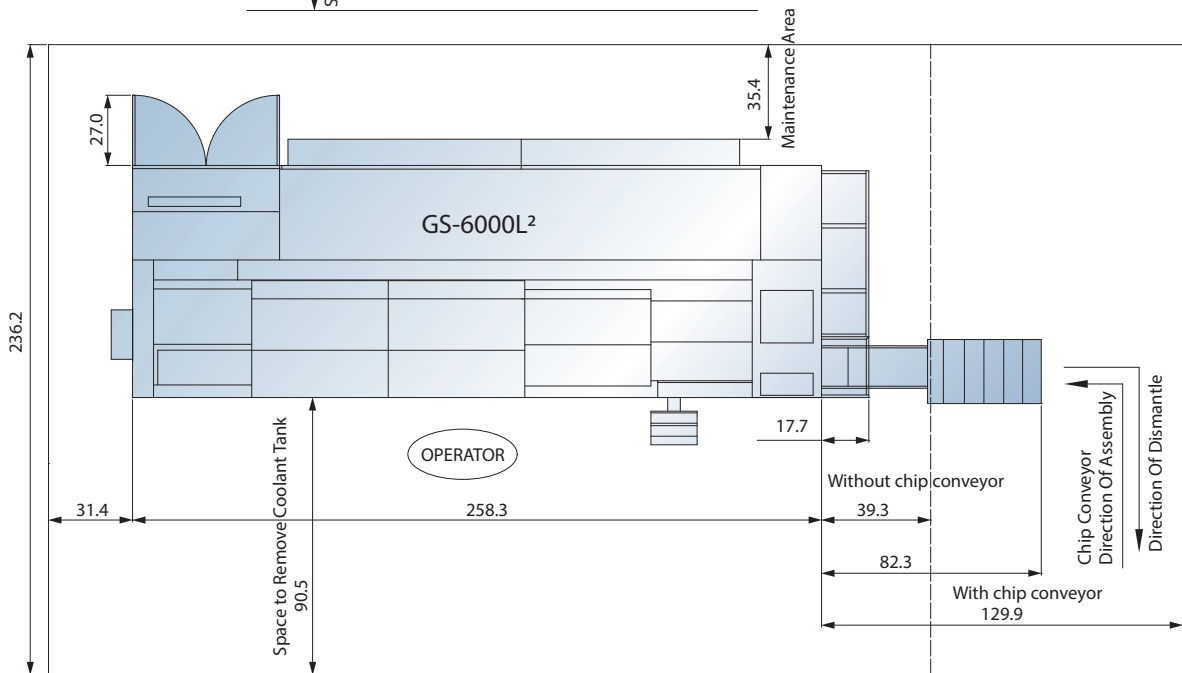
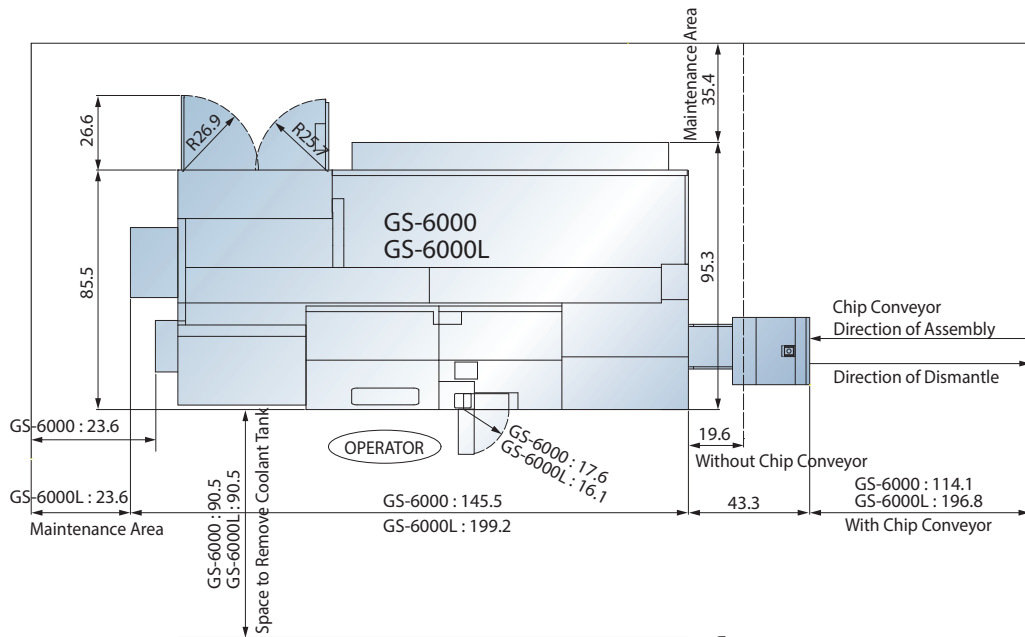

Machine Layout

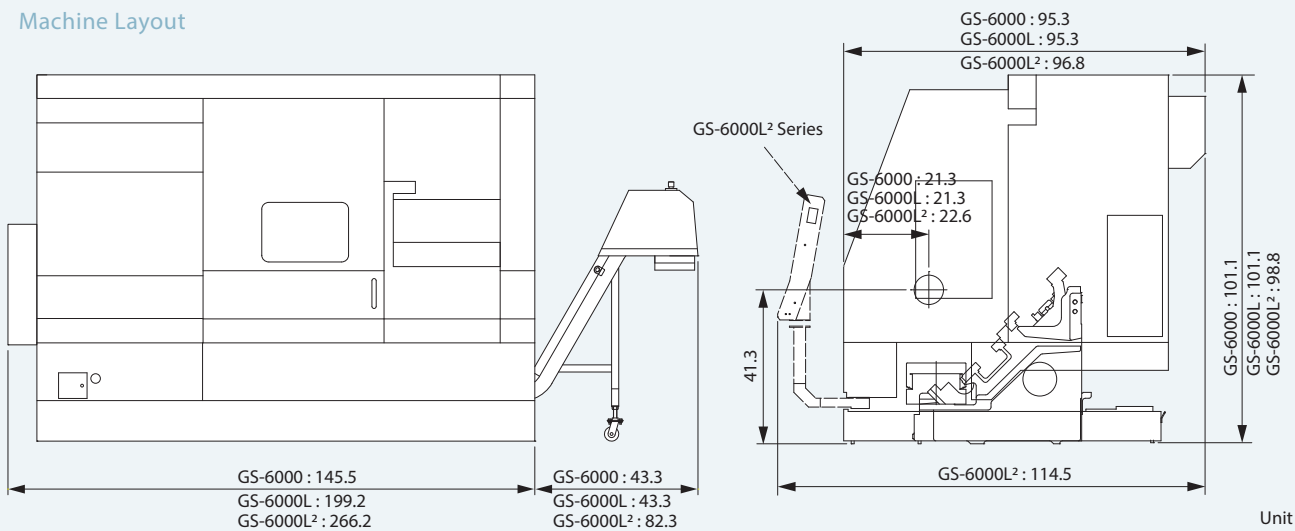

Unit : inch

Foundation Requirement

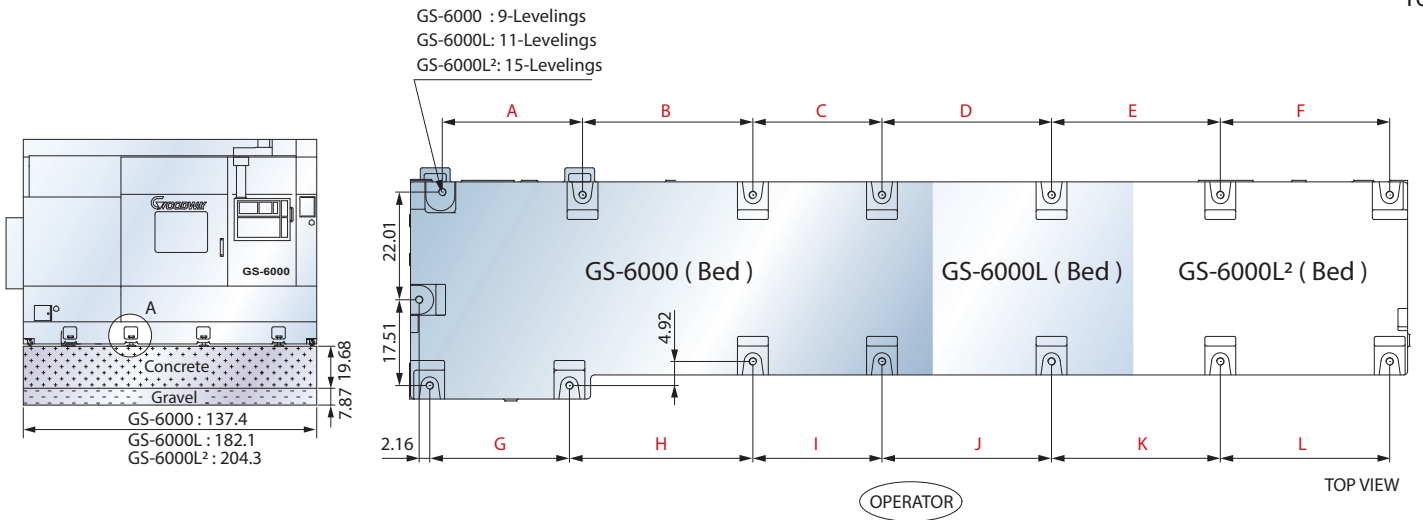

Unit : inch

Model	A	B	C	D	E	F	G	H	I	J	K	L
GS-6000	718 mm (28.26")	804 mm (31.65")	895 mm (35.23")	—	—	—	725 mm (28.54")	862 mm (33.93")	895 mm (35.23")	—	—	—
GS-6000L	718 mm (28.26")	884 mm (34.79")	976 mm (38.42")	879 mm (34.61")	—	—	725 mm (28.54")	942 mm (37.08")	976 mm (38.42")	879 mm (34.61")	—	—
GS-6000L²	718 mm (28.26")	884 mm (34.79")	770 mm (30.31")	880 mm (34.64")	776 mm (30.55")	879 mm (34.61")	725 mm (28.54")	942 mm (37.08")	770 mm (30.31")	880 mm (34.64")	786 mm (30.94")	879 mm (34.61")

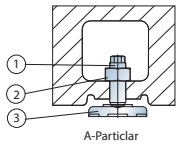

NO.	Part NO	Part name
1	CA-1029	Levelling Bolt
2	NA3900BA	Hex. Nut M39
3	CA-1030	Leveling Block

Lifting by Overhead Crane

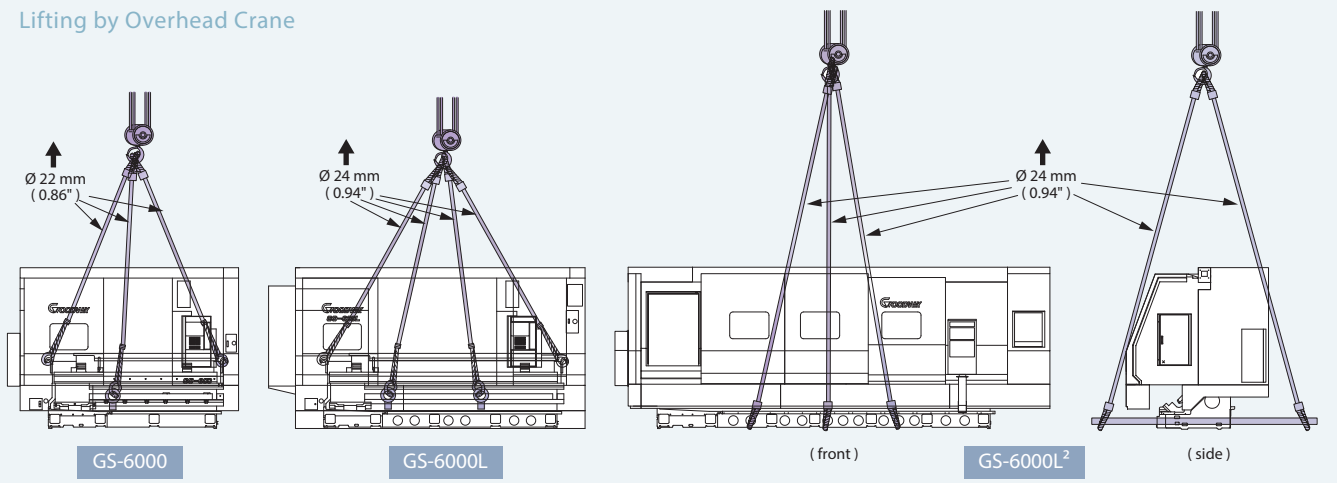

Lifting by Forklift

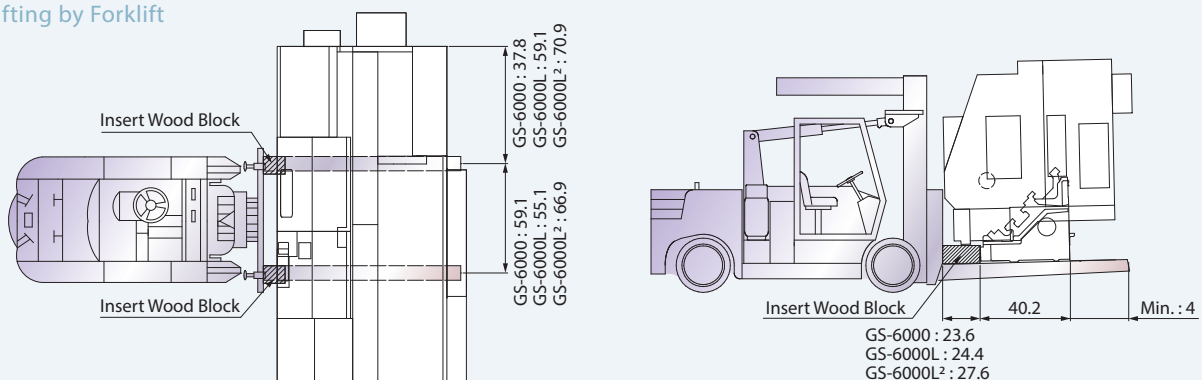

Unit : inch

MACHINE SPECIFICATIONS

CAPACITY		GS-6000 / L / L ²	GS-6600 / L / L ²		GS-6800 / L / L ²
Max. swing diameter		Ø 980 mm (38.58")			
Swing over saddle		Ø 710 mm (27.95")			
Max. turning diameter		Ø 880 mm (34.64")			
Max. turning length		950 / 1,980 / 3,300 mm (37.40" / 77.95" / 129.92")			
Chuck size		15" (Opt. 18")	20" (Opt. Hyd. Chuck)	22" (Opt. Air Chuck)	24" (Opt. Air Chuck)
Bar capacity		Ø 115 mm (4.52")	Ø 180 mm (7.08")	Ø 205 mm (8.07")	Ø 260 mm (10.24")
SPINDLE					
Hole through spindle		Ø 130 mm (5.11")	Ø 205 mm (8.07")		Ø 260 mm (10.24")
Spindle bearing diameter		Ø 180 mm (7.08")	Ø 260 mm (10.24")		Ø 340 mm (13.38")
Hydraulic cylinder		Ø 15"	Ø 20"	—	—
Spindle nose		A2-11	A2-15		A2-15
Motor output (Cont.)		30 kW (40 HP)			
Motor output (30 min.)		37 kW (50 HP)			
Motor full output speed		1,150 rpm			
Spindle drive system		V-Belt + Gear Box			
Spindle drive ratio	L	0.15	0.15		0.068
	H	0.54	0.54		0.271
Spindle speed range	L	550 rpm	550 rpm		400 rpm
	H	2,000 rpm	1,100 rpm		800 rpm
Spindle full output speed (30 min.)	L	2,048 N-m (1,510 lb-ft)	2,048 N-m (1,510 lb-ft)		1,133 N-m (835 lb-ft)
	H	567 N-m (418 lb-ft)	567 N-m (418 lb-ft)		4,533 N-m (3,343 lb-ft)
X & Z AXES					
Max. X-axis travel*1		500 mm (19.68")			
Max. Z-axis travel*1		980 / 1,965 / 3,300 mm (38.58" / 77.36" / 129.92")			
X-axis rapids		20 m/min (788 IPM)			
Z-axis rapids		24 / 24 / 12 m/min (945 / 945 / 472 IPM)			
Slide way type		Box Way			
Feed rates		1~ 4,800 mm / min (1~189 IPM)			
X-axis servo motor		AC 6 kW (8 HP)			
Z-axis servo motor		AC 7 kW (9.4 HP)			
X-axis ball screw Ø [pitch]		Ø 40 mm (1.57") [8 mm (0.31")]			
Z-axis ball screw Ø [pitch]		Ø 45 mm (1.77") [12 mm (0.47")] / Ø 50 mm (1.96") [16 mm (0.62")] / Ø 63 mm (2.48") [16 mm (0.62")]			
X / Z axes thrust (Cont.)		3,046 / 2,404 Kg (6,715 / 5,301 lb)			
TURRET					
Stations		12			
Indexing drive		FANUC AC Servo motor			
Indexing speed		0.5 sec. (Adjacent) / 1.5 sec. 180° (Single step)			
Accuracy		Positioning : ± 0.00069°, Repeatability : ± 0.00027°			
OD tool shank size		□ 32 mm (1-1/4")			
ID tool shank size		Ø 60 mm (2-1/2")			

LIVE TOOLING TURRET (OPT.)	GS-6000 / L / L²	GS-6600 / L / L²	GS-6800 / L / L²
Max. turning length	830 / 1,860 / 3,200 mm (32.67" / 73.22" / 125.98")		
Max. turning diameter	Ø 880 mm (34.64")		
Stations	12		
Live tooling stations	12 (Live tooling tools rotate in working position only)		
Live tooling drive motor (Cont. / 30 min.)	AC 7.5 / 9 kW (10 / 12 HP)		
Live tooling torque	120 N-m (88.5 lb-ft) @ 750 rpm (30 min.)		
Indexing drive type	FANUC AC Spindle motor		
Index speed	0.5 sec. (Adjacent) / 1.5 sec. 180 degree (Single step)		
OD tool shank size	□ 32 mm (1-1/4")		
ID tool shank size	Ø 60 mm (2-1/2")		
Live tooling shank size	ER 50 [Ø 30 mm (1.18")]		
Live tooling RPM range	10 ~ 3,000 rpm		
Cf-AXIS SPINDLE (OPT.)			
Cf-axis drive ratio	1 : 150		
Cf-axis rapids	20 rpm		
Cf-axis torque output (Cont.)	1,800 N-m (1,328 lb-ft)		
Min. spindle indexing angle	0.001°		
Dynamic accuracy	± 0.02°		
TAILSTOCK			
Quill center taper	MT#4 (Dead center) [Opt. MT#5 (Live center), MT#5 (Dead center), MT#6 (Live center)]		
Quill diameter / travel	Ø 110 / 150 mm (4.3" / 5.9") [Opt. Ø 160 / 150 mm (6.2" / 5.9") ^{*2} Ø 120 / 150 mm (4.7" / 5.9") ^{*3}]		
Tailstock base travel	800 / 1,750 / 3,200 mm (31.49" / 68.89" / 125.98")		
Programmable quill / base	Yes / Yes		
Programmable base type	Position by Z-axis		
GENERAL			
Positioning accuracy (X / Z)	0.015 mm / 100 mm ^{*4}		
Repeatability (X / Z)	± 0.003 mm ^{*4}		
CNC control	FANUC Oi-TD (Opt. 31i)		
Voltage / Power requirement	AC 200 / 220 +10% to -15% 3 phase / 55 KVA		
Air pressure	6 Kg / cm ² (85.2 PSI)		
Hydraulic tank capacity	15 L (3.3 gal)		
Coolant tank capacity	240 / 320 / 680 L (63.3 / 84.4 / 179.5 gal)		
Coolant pump	1 kW (1.5 HP) rated at 5 bar (71 PSI)		
Machine weight	12,000 / 14,000 / 18,000 Kg (26,400 / 30,800 / 39,600 lb)		
Dimensions L × W × H	3,696 x 2,422 x 2,570 / 5,060 x 2,422 x 2,570 / 6,764 x 2,910 x 2,510 mm (145.6" x 95.4" x 101.2" / 199.3" x 95.4" x 101.2" / 266.3" x 114.6" x 98.9")		

Specifications are subject to change without notice.

*1 The specification of each model may be slightly different, please refer to the interference diagram.

*2 Option dead center MT#5.

*3 Option live center MT#6.

*4 Measurement is based on JIS B 6331.



YAMA SEIKI USA., INC.

5788 Schaefer Ave., Chino, CA 91710

TEL : (888) 976-6789

(909) 628-5568

FAX : (909) 993-5378

Web : www.YAMASEIKI.com

E-mail : sales@YAMASEIKI.com