



AWEA MECHANTRONIC CO., LTD.

HEADQUARTERS

629, Suezhetou Section, Kwanpu Rd., Wenshan Li,
Hsinpu, Hsinchu 305, Taiwan
TEL : +886-3-588-5191
FAX : +886-3-588-5194
Website : www.awea.com

CENTRAL TAIWAN SCIENCE PARK BRANCH

15, Keyuan 2nd Rd., Central Taiwan Science Park,
Taichung 407, Taiwan
TEL : +886-4-2462-9698
FAX : +886-4-2462-8002
E-mail : sales@awea.com

ISO 9001



ISO 14001



SP / LP SERIES

Ultra Performance Bridge Type Vertical Machining Center



Ultra Performance Bridge Type Vertical Machining Center

Introducing AWEA with mature manufacturing abilities and advanced technology skills. The SP and LP series bridge type vertical machining centers combine strong spindle power and high rigidity structure along with high quality automation equipments and full product line to provide you with high efficiency, high productivity machining strategies; it can be broadly applied in the automotive, precision mold, aerospace and energy industries., etc.

The LP series can be equipped with an automatic head changer and vertical / horizontal ATC system which turns into a 5-face machining center providing more cutting flexibility to meet your demands of today and tomorrow.

SP Series Product Map

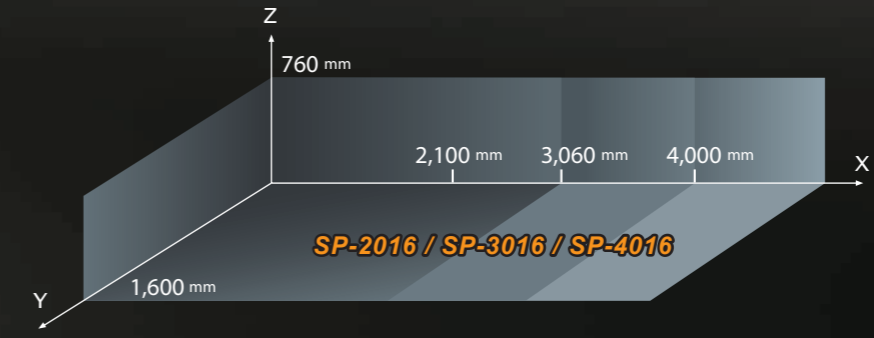

LP Series Product Map

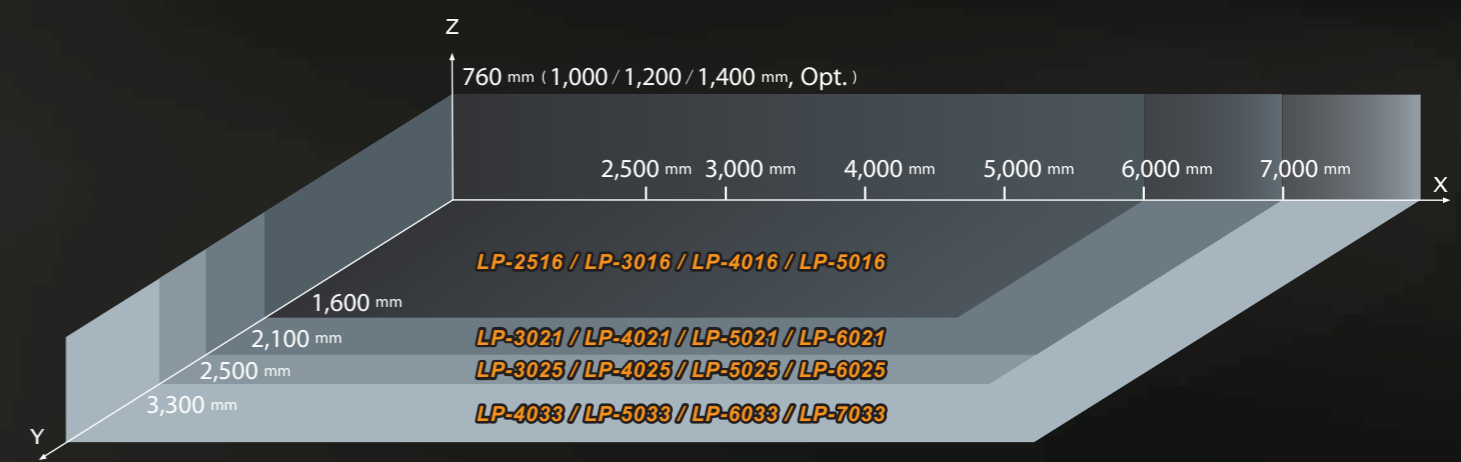

SP Series 2016 / 3016 / 4016

Ultra Performance Bridge Type Vertical Machining Center

Thanks to our advanced developing skills and strict assembly process, gives the SP series ultra performance bridge type vertical machining center optimum rigidity, accuracy and efficiency.

- The modular spindle design provides cutting flexibility for various working conditions.
- High rigidity roller type linear guide ways on the X, Y axes offer heavy-duty cutting, fast movement and low abrasion capabilities.
- The Z-axis is adopted with high rigidity box way which is hardened and precisely ground suitable for heavy-duty cutting conditions. (Opt. : The Z-axis can be adopted with roller type linear guide ways if equipped with high speed direct driven spindle.)



Extension operator door (Opt.)

Ultra Performance Bridge Type Vertical Machining Center

High Rigidity Structure

- One-piece bridge and base casting structure with hand scraped contact surfaces ensure optimum assembly precision, structural rigidity and load balancing.
- Rib reinforced working table restrains vibration while increasing machining stability.
- The Finite Element Method (FEM) analysis provides optimum machine design and light-weighted structure advantages while ensuring best machine rigidity.



■ Precision Hand Scraping

All contact surfaces are precisely hand scraped to ensure maximum precision and rigidity.

■ Axial Torque Clutch

Three axes ball screws are equipped with mechanical torque clutches to minimize damages due to over load issues or crash.



■ Precision Feedback System

The semi-closed loop circuit system which the ball screw end is directly connected to the encoder ensures high positioning accuracy.



LP Series 2516 / 3016 / 4016 / 5016 / 3021 / 4021 / 5021 / 6021
3025 / 4025 / 5025 / 6025 / 4033 / 5033 / 6033 / 7033

Ultra Performance Bridge Type Vertical Machining Center

Complete product line with full range specifications, the LP series can be equipped with high flexibility automatic head changer and vertical / horizontal ATC system to provide full automation 5-face machining capability.

- The modular spindle design provides cutting flexibility for different working conditions.
- High rigidity roller type linear guide ways on the X, Y axes offer heavy-duty cutting, fast movement and low abrasion capabilities.
- The Z-axis is adopted with high rigidity box way which is hardened and precisely ground suitable for heavy-duty cutting conditions. (Opt. : The Z-axis can be adopted with roller type linear guide ways if equipped with high speed direct driven spindle.)



Fully enclosed splash guard with roof; 1,000 mm Z-axis travel (Opt.)

LP

Series 2516 / 3016 / 4016 / 5016 / 3021 / 4021 / 5021 / 6021
3025 / 4025 / 5025 / 6025 / 4033 / 5033 / 6033 / 7033

Ultra Performance Bridge Type Vertical Machining Center

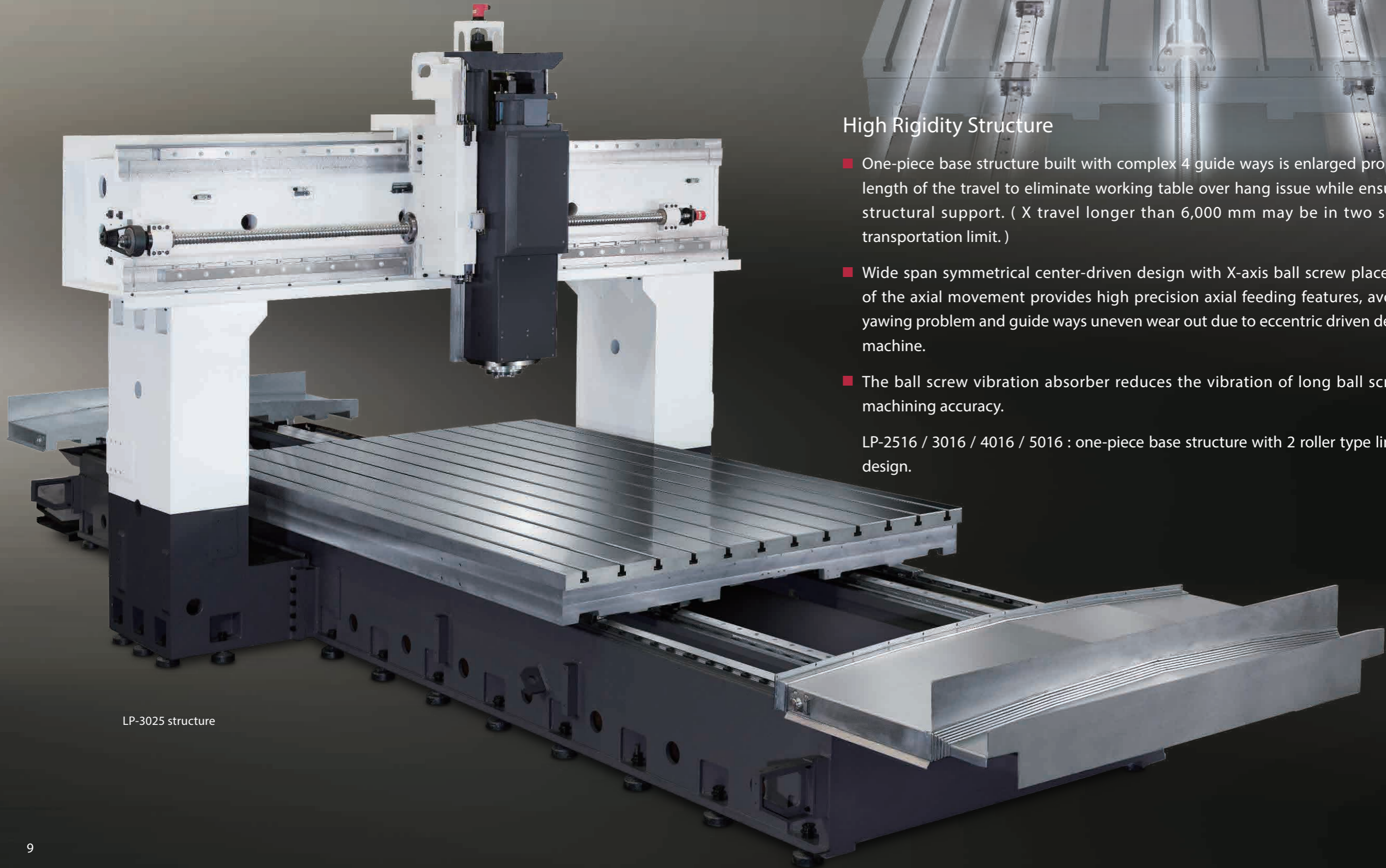

LP-3025 structure

High Rigidity Structure

- One-piece base structure built with complex 4 guide ways is enlarged proportional to the length of the travel to eliminate working table over hang issue while ensuring maximum structural support. (X travel longer than 6,000 mm may be in two sections due to transportation limit.)
- Wide span symmetrical center-driven design with X-axis ball screw placed in the center of the axial movement provides high precision axial feeding features, avoids movement yawing problem and guide ways uneven wear out due to eccentric driven design as in other machine.
- The ball screw vibration absorber reduces the vibration of long ball screw to increase machining accuracy.

LP-2516 / 3016 / 4016 / 5016 : one-piece base structure with 2 roller type linear guide ways design.

High Flexibility 5-face Machining Capability Automatic Head Changer And Vertical / Horizontal ATC System

- The LP series can be equipped with automatic head changer and vertical / horizontal ATC system to provide maximum efficiency as of a 5-face machining center.
- Automatic head storage magazine provides two cabinets for both horizontal head and spindle cap. Linear guide way sliding design provides quick head change to reduce non-cutting time. Each cabinet is equipped with independent swing door, only opens when is exchanging, which eliminates the contamination in head storage for longer life time.
- The vertical / horizontal ATC system provides quick tool change with sensors and sequence scanning to ensure safety and reliability.
- 32-tool ATC system (Std.), 60-tool / 90-tool / 120-tool ATC system (Opt.).



LP-7033F with 4-piece splash guard



LP-5025F fully enclosed splash guard with roof (Opt.)

Optimum Spindle System

Powerful Cutting Capability

Inner-rail embraced structure provides high rigidity and gains good stress flow which minimizes over hang and vibration issues. The Y-axis roller type linear guide ways offset from each other increases structural rigidity reduces distance between spindle to cross beam enhances overall cutting performance.

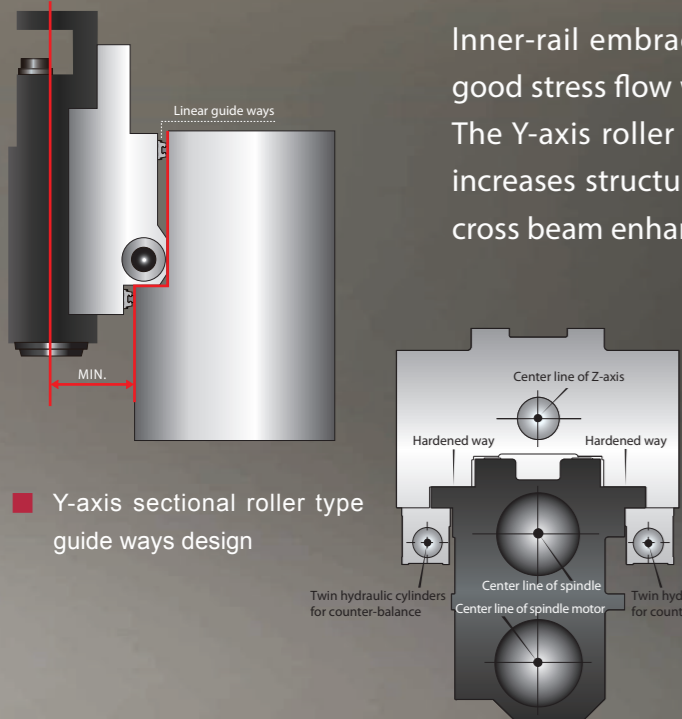

■ Y-axis sectional roller type guide ways design

■ Centro-symmetric main spindle system design

Centro-symmetric Main Spindle System

Unique head design which the main spindle, spindle motor, ball screw and hydraulic counter weight cylinders are symmetrically placed. Hereby preventing thermal distortion and minimizing deflection. Assuring accuracy and heavy cutting capability.

977 N-m

Maximum Torque



High Torque Gear Spindle

- 2-speed super heavy-duty gear box.
- Floating type hydraulic tool release device eliminates pressure on the spindle bearing when releasing a tool.
- 4,000 rpm high torque spindle is equipped with powerful 26 kW motor delivers maximum torque output of 977 N-m at 254 rpm to meet with various heavy-duty cutting conditions.
- 6,000 rpm high torque spindle is equipped with powerful 26 kW motor delivers maximum torque output of 642 N-m at 387 rpm.

High Speed, High Torque Built-in Motorized Spindle

- The built-in motor design reduces centrifugal force effect and restrains spindle vibration, which increases the spindle life span and improves long-term machining accuracy.
- Floating type hydraulic tool release device eliminates pressure on the spindle bearing when releasing a tool.
- 6,000 rpm and 8,000 rpm are available, which provides maximum 600 N-m torque output at 350 rpm to meet with various working conditions.

High Speed, High Power Direct-driven Spindle

- Direct-driven spindle efficiently separates the heat generated from the motor, which reduces deformation, therefore, increasing machining accuracy.
- Floating type hydraulic tool release device eliminates pressure on the spindle bearing when releasing a tool.
- 8,000 rpm and 10,000 rpm are available, which provides maximum 165 N-m torque output at 1,500 rpm to meet with various high speed working conditions.

4,000 rpm Gear Spindle

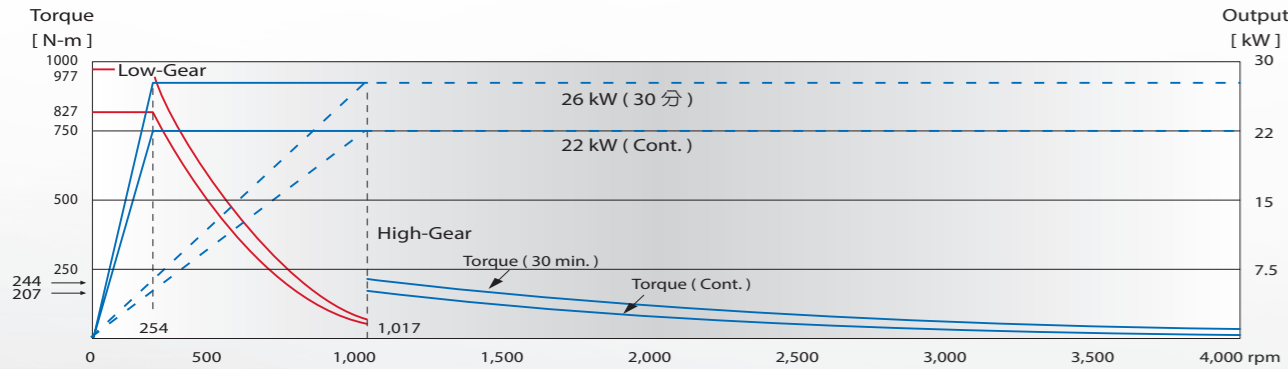

6,000 rpm Built-in Motorized Spindle

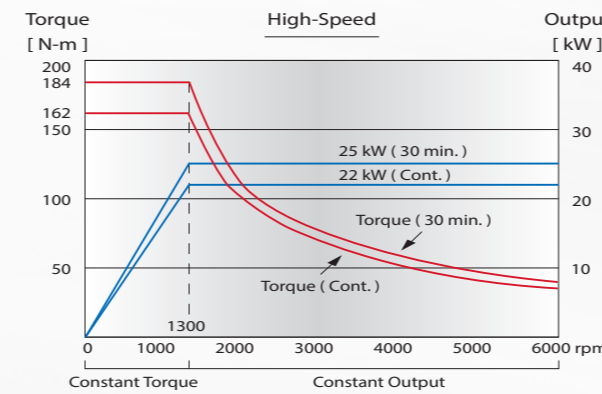
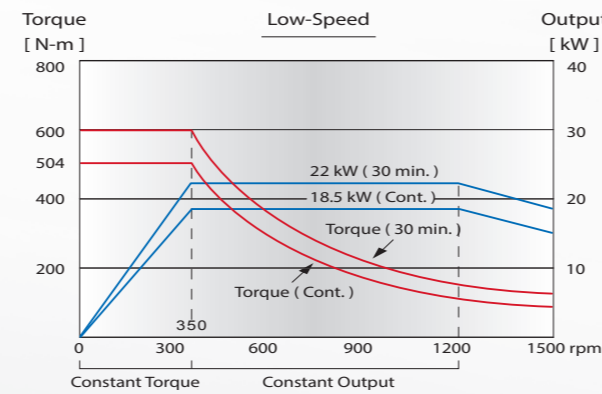

8,000 rpm Direct-driven Spindle

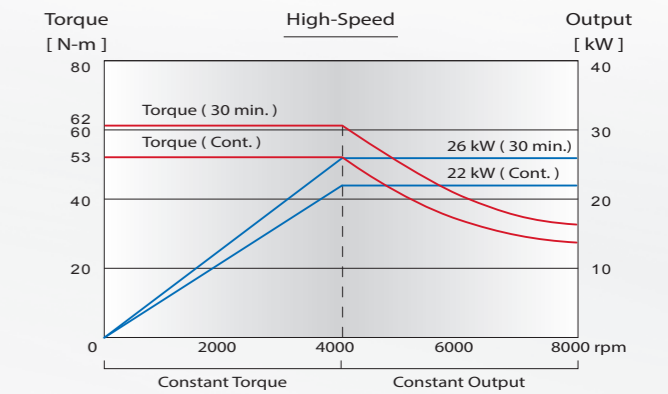
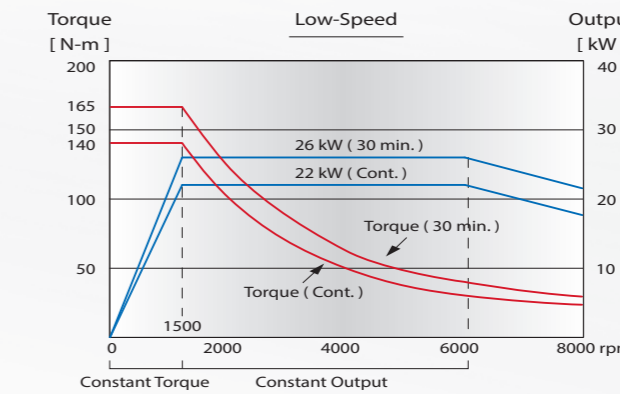

6,000 rpm Gear Spindle

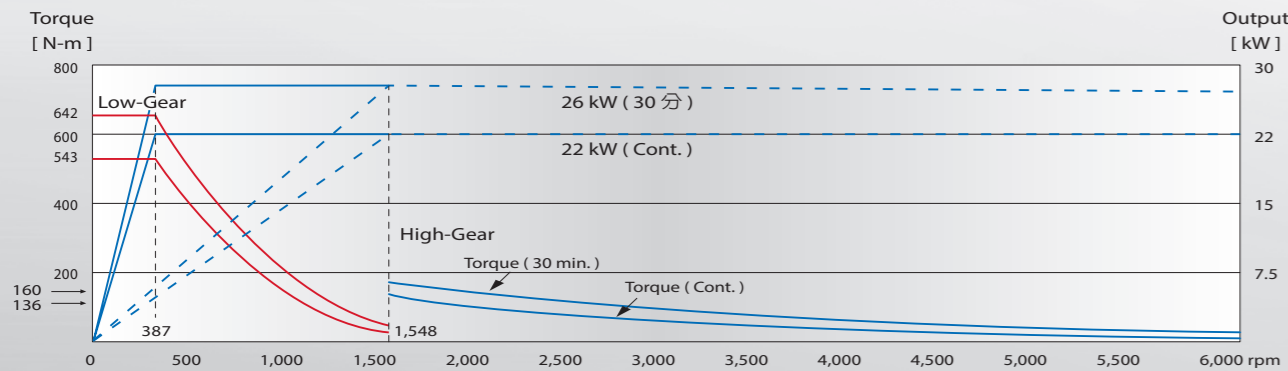

8,000 rpm Built-in Motorized Spindle

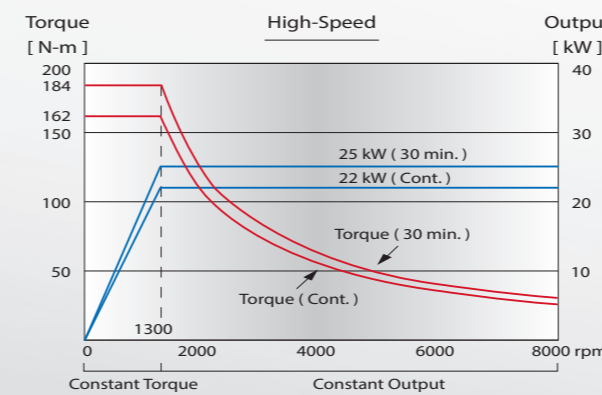
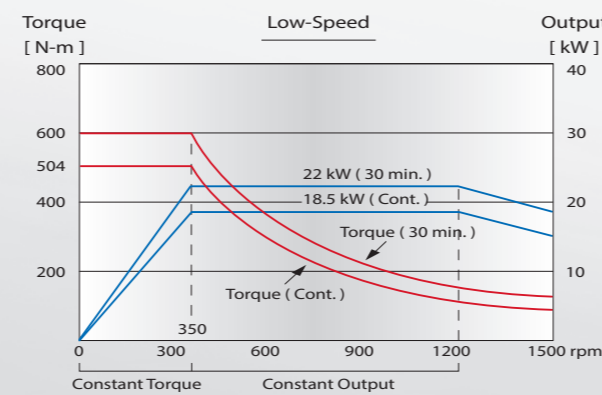

10,000 rpm Direct-driven Spindle

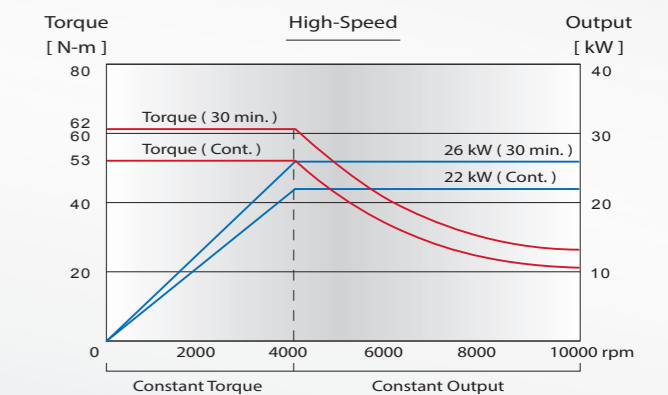
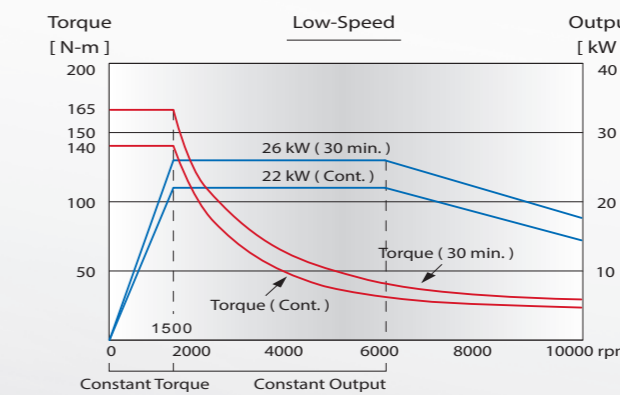

Multi-purpose Milling Head Combination

- All milling heads includes 35° head, 90° head, extension head and universal head are self developed and assembled.
- The contact surface of all milling heads and covers are precisely hand scraped while using the Japanese 2-piece curvic coupling for precision positioning.
- The automatic milling head can be controlled by programming.

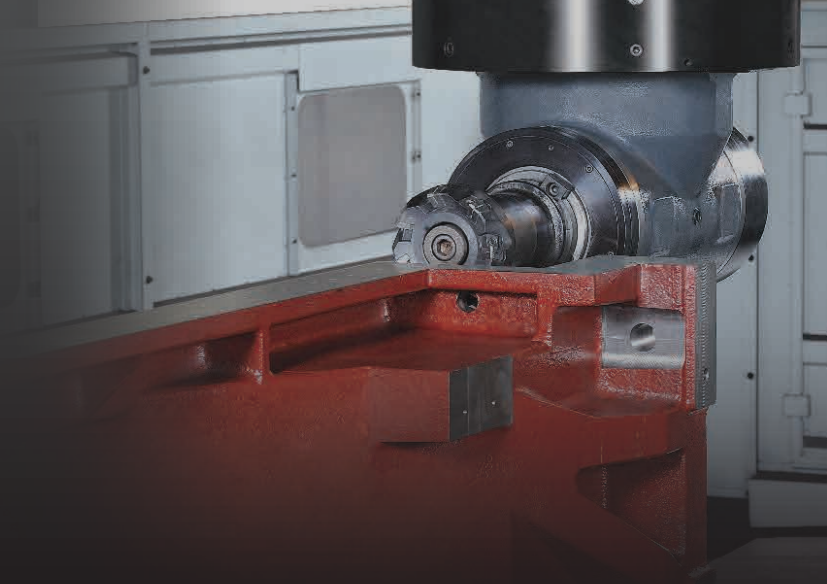

Optional Milling Head (Manual)

(Unit : mm)

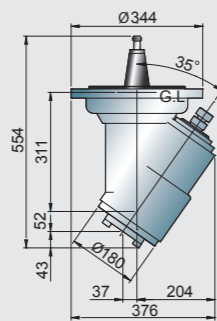

35° Head

Manual head / tool lock
Manual 90° index
Max. speed : 2,000 rpm
Max. output : 22 kW (30 HP)

Optional Milling Head (Automatic)

(Unit : mm)

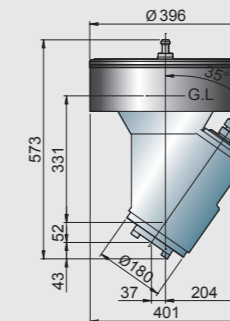

35° Head

Automatic head lock / manual tool lock
Cs-axis automatic 5° index
Max. speed : 2,000 rpm
Max. output : 22 kW (30 HP)

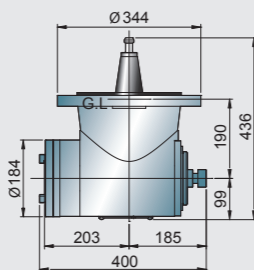

90° Head

Manual head / tool lock
Manual 90° index
Max. speed : 2,000 rpm
Max. output : 22 kW (30 HP)

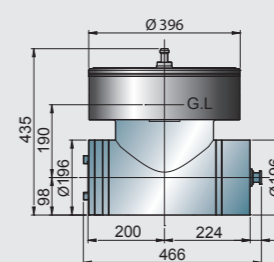

90° Head

Automatic head lock / automatic tool lock
Cs-axis automatic 5° index
Max. speed : 2,000 rpm
Max. output : 22 kW (30 HP)

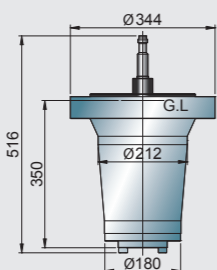

Extension Head

Manual head lock / hydraulic tool release (manual tool lock)
No index function
Max. speed : 3,000 rpm
Max. output : 22 kW (30 HP)

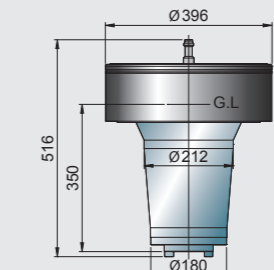

Extension Head

Automatic head lock / hydraulic tool lock
No index function
Max. speed : 3,000 rpm
Max. output : 22 kW (30 HP)

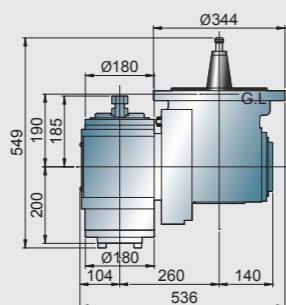

Universal Head

Manual head / tool lock
Cs-axis manual 90° index (A-axis manual)
Max. speed : 2,000 rpm
Max. output : 22 kW (30 HP)

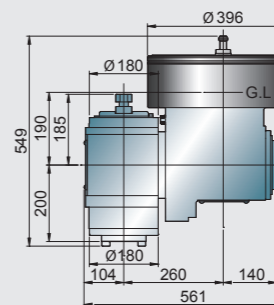
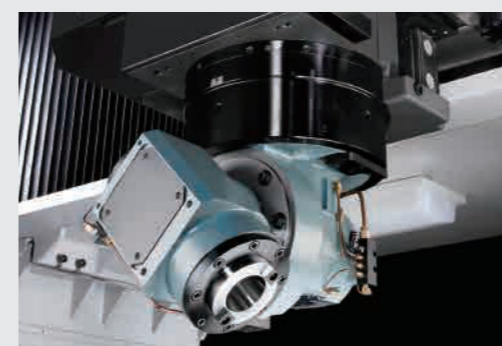

Universal Head

Automatic head lock / manual tool lock
Cs-axis automatic 5° index (A-axis manual)
Max. speed : 2,000 rpm
Max. output : 22 kW (30 HP)

Dimensions

Table Dimensions

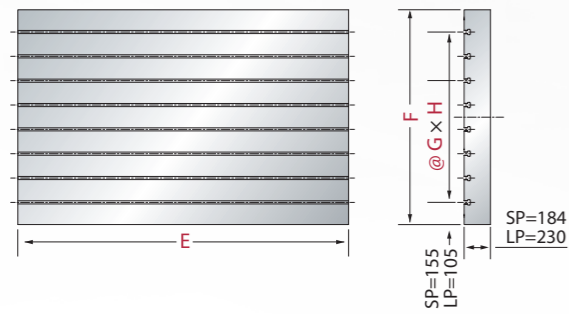

T-slot Dimensions

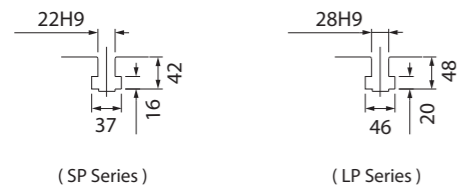

Machine Dimensions

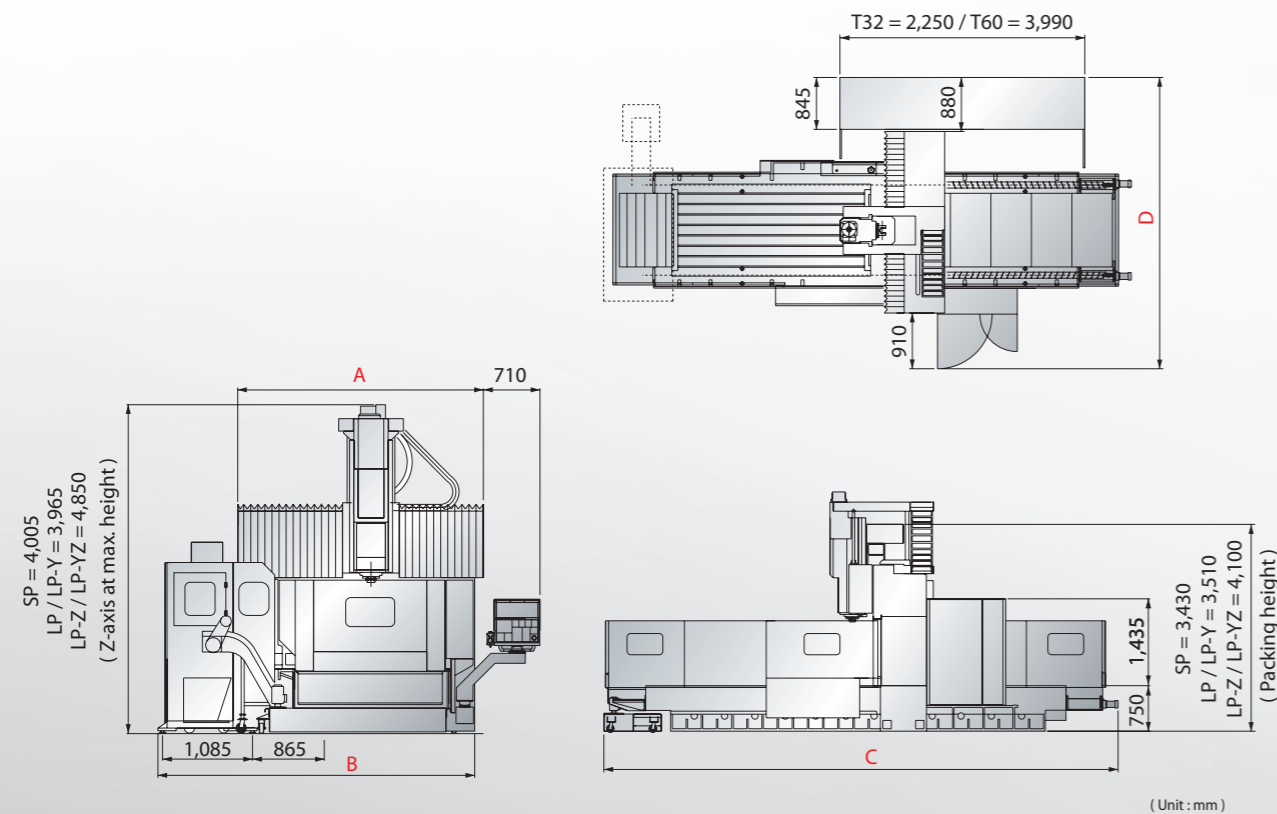

Tool Shank and Pull Stud Dimensions

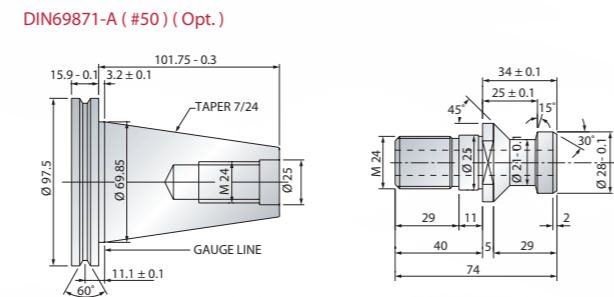
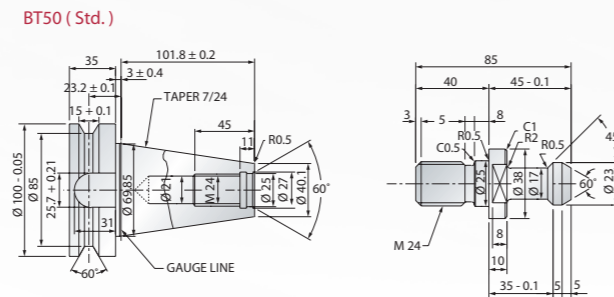

Models	A	B	C	D	E	F	G	H	
SP	2016	2,990	3,820	6,675	4,840	2,310	1,500	170	7
	3016	2,990	3,820	8,660	4,840	3,260	1,500	170	7
	4016	2,990	3,820	10,660	4,840	4,200	1,500	170	7
LP	2516	3,170	3,950	8,210	4,580	2,310	1,500	170	7
	3016	3,170	3,950	8,710	4,580	3,260	1,500	170	7
	4016	3,170	3,950	10,710	4,580	4,200	1,500	170	7
	5016	3,170	3,950	12,710	4,580	5,000	1,500	170	7
	3021	3,650	4,550	8,580	5,375	3,020	2,010	200	9
	4021	3,650	4,550	10,580	5,375	4,020	2,010	200	9
	5021	3,650	4,550	12,680	5,375	5,020	2,010	200	9
	6021	3,650	4,550	14,680	5,375	6,020	2,010	200	9
	3025	4,050	4,950	8,580	5,775	3,020	2,400	200	11
	4025	4,050	4,950	10,580	5,775	4,020	2,400	200	11
	5025	4,050	4,950	12,680	5,775	5,020	2,400	200	11
	6025	4,050	4,950	14,680	5,775	6,020	2,400	200	11
	4033	4,850	5,750	10,580	6,575	4,020	2,400	200	11
5033	4,850	5,750	12,680	6,575	5,020	2,400	200	11	
6033	4,850	5,750	14,680	6,575	6,020	2,400	200	11	
7033	4,850	5,750	16,630	6,575	7,020	2,400	200	11	

Models	A	B	C	D	E	F	G	H	
LP	3021Y	4,050	4,950	8,580	5,375	3,020	2,010	200	9
	4021Y	4,050	4,950	10,580	5,375	4,020	2,010	200	9
	5021Y	4,050	4,950	12,680	5,375	5,020	2,010	200	9
	6021Y	4,050	4,950	14,680	5,375	6,020	2,010	200	9
	4025Y	4,850	5,750	10,580	5,775	4,020	2,400	200	11
	5025Y	4,850	5,750	12,680	5,775	5,020	2,400	200	11
	6025Y	4,850	5,750	14,680	5,775	6,020	2,400	200	11
	5033Y	5,490	5,750	12,680	6,575	5,020	2,400	200	11
6033Y	5,490	5,750	14,680	6,575	6,020	2,400	200	11	
7033Y	5,490	5,750	16,630	6,575	7,020	2,400	200	11	

Models	A	B	C	D	E	F	G	H	
LP	3021Z	4,160	4,850	8,580	5,375	3,020	2,010	200	9
	4021Z	4,160	4,850	10,580	5,375	4,020	2,010	200	9
	5021Z	4,160	4,850	12,680	5,375	5,020	2,010	200	9
	3025Z	4,560	5,250	8,580	5,775	3,020	2,400	200	11
	4025Z	4,560	5,250	10,580	5,775	4,020	2,400	200	11
	5025Z	4,560	5,250	12,680	5,775	5,020	2,400	200	11
	6025Z	5,730	5,250	14,680	5,775	6,020	2,400	200	11
	4033Z	5,370	6,050	10,580	6,575	4,020	2,400	200	11
	5033Z	5,370	6,050	12,680	6,575	5,020	2,400	200	11
	6033Z	5,370	6,050	14,680	6,575	6,020	2,400	200	11
7033Z	5,370	6,050	16,630	6,575	7,020	2,400	200	11	

* This chart is based on 1,000 mm Z travel; please contact AWEA for 1,200 or 1,400 mm dimensions.

Models	A	B	C	D	E	F	G	H	
LP	3025YZ	5,235	6,050	8,580	6,175	3,020	2,400	200	11
	4025YZ	5,235	6,050	10,580	6,175	4,020	2,400	200	11
	5025YZ	5,235	6,050	12,680	6,175	5,020	2,400	200	11
	6025YZ	5,235	6,050	14,680	6,175	6,020	2,400	200	11
	4033YZ	6,060	6,750	10,580	6,735	4,020	2,400	200	11
	5033YZ	6,060	6,750	12,680	6,735	5,020	2,400	200	11
	6033YZ	6,060	6,750	14,680	6,735	6,020	2,400	200	11
7033YZ	6,060	6,750	16,630	6,735	7,020	3,010	200	14	

* This chart is based on 1,000 mm Z travel ; please contact AWEA for 1,200 or 1,400 mm dimensions.

Specifications are subject to change without notice.

i Console

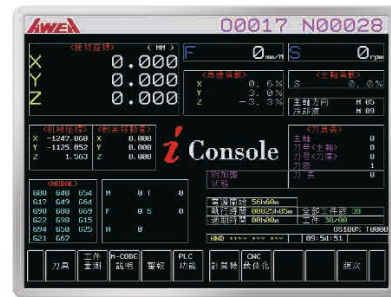

Multiple Functions Status Display

- Real time operation information
- Tool list
- Work piece measurement
- M code illustration
- PLC function
- Calculator
- CNC optimize parameter (Opt.)
- Spindle thermal compensation (Opt.)



Trouble Shooting

When the alarm appears, the program will display the breakdown cause and a troubleshooting procedure. Users can easily troubleshoot minor problems to save machine shutdown time.

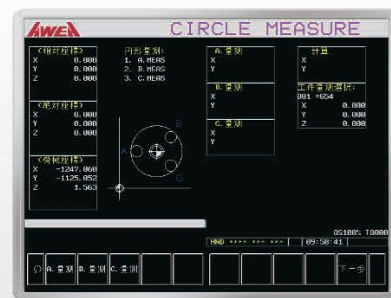

Circular Work Piece Measurement

The circular work piece program can calculate the center coordinate of a work piece by measuring point A, B and C coordinates.



CNC Optimized Parameter

From rough cutting to fine machining, users can select different working modes, determine the allowable tolerance and the weight of the work piece, based on your desired working condition.

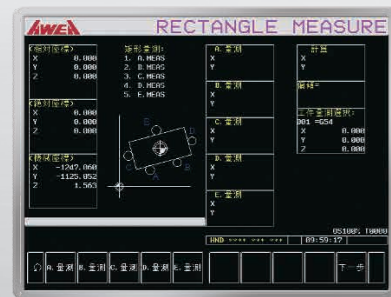

Rectangular Work Piece Measurement

The rectangular work piece program can calculate the center coordinate and the slant angle of a work piece by measuring point A, B, C, D and E coordinates; the calculated center coordinate can be inputted into the work piece coordinate program (G54 ~ G59).

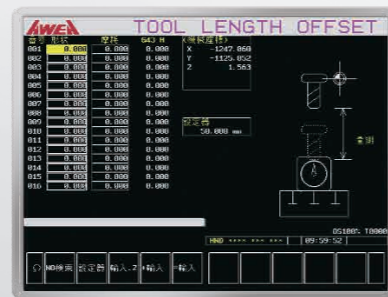

Manual Tool Length Measurement

After manually measuring the tool length, the controller will automatically calculate the tool tip position and input the data into the tool length offset table.

	SP-2016	SP-3016	SP-4016	LP-2516	LP-3016	LP-4016	LP-5016
--	---------	---------	---------	---------	---------	---------	---------

SPECIFICATIONS								
X-axis travel	mm	2,100	3,060	4,000	2,500	3,000	4,000	5,000
Y-axis travel	mm	1,600						
Z-axis travel	mm	760						
Distance from spindle nose to table top	mm	240 ~ 1,000						
Distance between columns	mm	1,700						

WORKING TABLE								
Table size (X direction)	mm	2,310	3,260	4,200	2,310	3,260	4,200	5,000
Table size (Y direction)	mm	1,500						
Table load capacity	kg	8,000	10,000	12,000	8,000	10,000	12,000	14,000

SPINDLE							
Spindle taper		BT50 (ISO50) / DIN69871-A (Opt.)					
Spindle motor (cont. / 30 min.)	kW (HP)	22 / 26 (30 / 35)					
Spindle speed	rpm	6,000					

FEED RATE								
X-axis rapid feed rate	mm/min	20,000	20,000	15,000	20,000	20,000	15,000	10,000
Y / Z axes rapid feed rate	mm/min	20,000 / 15,000						
Cutting feed rate	mm/min	1 ~ 10,000						

TOOL MAGAZINE							
Tool magazine capacity	T	32 (60 / 90 / 120 Opt.)			32 (40 Opt.)		
Max. tool diameter / adj. pocket empty	mm	Ø127 / Ø215					
Max. tool length (from gauge line)	mm	350			400		
Max. tool weight	kg	20					

ACCURACY								
Positioning accuracy (JIS B 6338)	mm	± 0.015 / Full Travel						
Positioning accuracy (VDI 3441)	mm	P ≤ 0.020 / Full Travel	P ≤ 0.025 / Full Travel	P ≤ 0.030 / Full Travel	P ≤ 0.020 / Full Travel	P ≤ 0.025 / Full Travel	P ≤ 0.030 / Full Travel	P ≤ 0.040 / Full Travel
Repeatability (JIS B 6338)	mm	± 0.003						
Repeatability (VDI 3441)	mm	Ps ≤ 0.015	Ps ≤ 0.020	Ps ≤ 0.025	Ps ≤ 0.015	Ps ≤ 0.020	Ps ≤ 0.025	Ps ≤ 0.030

GENERAL								
Power requirement		220 ± 10 %						
Pneumatic pressure requirement	kg/cm ²	5 ~ 8						
Hydraulic unit tank capacity (pump)	liter (HP)	120 (10)			120 (7.5)			
Lubrication oil tank capacity	liter	6						
Coolant tank capacity (pump)	liter (HP)	420 (1.5)						
Machine weight	kg	23,000	28,000	33,000	26,000	29,000	33,000	36,000

Standard Accessories

- Spindle cooling system
- Centralized automatic lubricating system
- Fully enclosed splash guard w/o roof (SP and LPXX16 series)
- 4 pcs splash guard (LP series)
- Coolant system with pump and tank
- Twin screw type chip conveyor
- Caterpillar type chip conveyor and bucket
- Foundation bolt kit
- Tool box
- Alarm light
- Water gun
- Automatic power off system

Optional Accessories

- Spindle:
 - 4,000 rpm gear spindle
 - 8,000 / 10,000 rpm direct-driven spindle
 - 6,000 / 8,000 rpm built-in motorized spindle
- Spindle taper : DIN50 / CAT50 / ISO50
- Y travel extension : 2,500 / 3,200 / 4,000 mm
- Z travel extension : 1,000 / 1,200 / 1,400 mm
- Column extension : 200 / 300 / 400 / 500 mm
- Milling head (Manual) :
 - 35° / 90° / Extension / Universal Head
- Milling head (Automatic) :
 - 35° / 90° / Extension / Universal Head
- Tool magazine : 60 / 90 / 120 T
- X / Y / Z axes optical linear scale (HEIDENHAIN)
- Spindle thermal compensation
- Coolant through the tool adapter
- Coolant through the spindle (Form A)
- Automatic tool length measurement
- Automatic work piece measurement
- CNC rotary table
- Oil skimmer
- Oil mist cooling system

		LP-3021	LP-4021	LP-5021	LP-6021	LP-3025	LP-4025	LP-5025	LP-6025	LP-4033	LP-5033	LP-6033	LP-7033	
SPECIFICATIONS														
X-axis travel	mm	3,000	4,000	5,000	6,000	3,000	4,000	5,000	6,000	4,000	5,000	6,000	7,000	
Y-axis travel	mm	2,100 (2,500 Opt.)				2,500 (3,200 Opt.)				3,300 (4,000 Opt.)				
Z-axis travel	mm	760 (1,000 / 1,200 / 1,400 Opt.)												
Distance from spindle nose to table top	mm	240 ~ 1,000 (200 ~ 1,200 / 200 ~ 1,400 / 200 ~ 1,600 Opt.)												
Distance between columns	mm	2,300				2,700				3,500				
WORKING TABLE														
Table size (X direction)	mm	3,020	4,020	5,020	6,020	3,020	4,020	5,020	6,020	4,020	5,020	6,020	7,020	
Table size (Y direction)	mm	2,010				2,400				2,400				3,010
Table load capacity	kg	10,000	12,000	15,000	18,000	12,000	15,000	18,000	20,000	15,000	18,000	20,000	20,000	
SPINDLE														
Spindle taper		BT50 (ISO 50) / DIN69871-A (Opt.)												
Spindle motor (cont. / 30 min.)	kW (HP)	22 / 26 (30 / 35)												
Spindle speed	rpm	6,000 (Std.) Z-axis : 1,000 / 1,200 / 1,400 mm ; 4,000 / 5,000 Gear Spindle (Opt.) : 6,000 / 8,000 Built-in Spindle (Opt.) : 8,000 / 10,000 Direct-driven Spindle (Opt.)												
FEED RATE														
X-axis rapid feed rate	mm/min	20,000	15,000	10,000	10,000	20,000	15,000	10,000	10,000	15,000	10,000	10,000	7,500	
Y / Z axes rapid feed rate	mm/min	15,000												
Cutting feed rate	mm/min	1 ~ 10,000	1 ~ 10,000	1 ~ 10,000	1 ~ 5,000	1 ~ 10,000	1 ~ 10,000	1 ~ 10,000	1 ~ 5,000	1 ~ 10,000	1 ~ 5,000	1 ~ 5,000	1 ~ 5,000	
TOOL MAGAZINE														
Tool magazine capacity	T	32 (60 / 90 / 120 Opt.)												
Max. tool diameter / adj. pocket empty	mm	Ø127 / Ø215												
Max. tool length (from gauge line)	mm	350												
Max. tool weight	kg	20												
ACCURACY														
Positioning accuracy (JIS B 6338)	mm	± 0.015 / Full Travel												± 0.010 / Full Travel
Positioning accuracy (VDI 3441)	mm	P ≤ 0.025 / Full Travel	P ≤ 0.030 / Full Travel	P ≤ 0.040 / Full Travel	P ≤ 0.050 / Full Travel	P ≤ 0.025 / Full Travel	P ≤ 0.030 / Full Travel	P ≤ 0.040 / Full Travel	P ≤ 0.050 / Full Travel	P ≤ 0.030 / Full Travel	P ≤ 0.040 / Full Travel	P ≤ 0.050 / Full Travel	P = 0.040 / Full Travel	
Repeatability (JIS B 6338)	mm	± 0.003												
Repeatability (VDI 3441)	mm	Ps ≤ 0.020	Ps ≤ 0.025	Ps ≤ 0.030	Ps ≤ 0.035	Ps ≤ 0.020	Ps ≤ 0.025	Ps ≤ 0.030	Ps ≤ 0.035	Ps ≤ 0.025	Ps ≤ 0.030	Ps ≤ 0.035	Ps = 0.030	
GENERAL														
Power requirement		220 ± 10 %												
Pneumatic pressure requirement (min.)	kg/cm ²	5 ~ 8 (5)												
Hydraulic unit tank capacity (pump)	liter	120 (10 HP)												
Lubrication oil tank capacity	liter	6												
Coolant tank capacity (pump)	liter	650 (1.5 HP)				750 (1.5 HP)								
Machine weight	kg	33,000	38,000	41,000	45,000	36,000	40,000	44,000	50,000	47,000	50,000	58,000	75,000	

Specifications are subject to change without notice.

Standard Accessories

- Spindle cooling system
- Centralized automatic lubricating system
- Fully enclosed splash guard w/o roof (SP and LPXX16 series)
- 4 pcs splash guard (LP series)
- Coolant system with pump and tank
- Twin screw type chip conveyor
- Caterpillar type chip conveyor and bucket
- Foundation bolt kit

- Tool box
- Alarm light
- Air gun
- Automatic power off system

Optional Accessories

- Spindle:
 - 4,000 rpm gear spindle
 - 8,000 / 10,000 rpm direct-driven spindle
 - 6,000 / 8,000 rpm built-in motorized spindle
- Spindle taper : DIN50 / CAT50 / ISO50
- Y travel extension : 2,500 / 3,200 / 4,000 mm
- Z travel extension : 1,000 / 1,200 / 1,400 mm
- Column extension : 200 / 300 / 400 / 500 mm

- Milling head (Manual) :
 - 35° / 90° / Extension / Universal Head
- Milling head (Automatic) :
 - 35° / 90° / Extension / Universal Head
- Tool magazine : 60 / 90 / 120 T
- X / Y / Z axes optical linear scale (HEIDENHAIN)
- Spindle thermal compensation
- Coolant through the tool adapter

- Coolant through the spindle (Form A)
- Automatic tool length measurement
- Automatic work piece measurement
- CNC rotary table
- Oil skimmer
- Oil mist cooling system