



AWEA MECHANTRONIC CO., LTD.

HEADQUARTERS

629, Suezhetou Section, Kwanpu Rd., Wenshan Li,
Hsinpu, Hsinchu 305, Taiwan
TEL : +886-3-588-5191
FAX : +886-3-588-5194
Website : www.awea.com

CENTRAL TAIWAN SCIENCE PARK BRANCH

15, Keyuan 2nd Rd., Central Taiwan Science Park,
Taichung 407, Taiwan
TEL : +886-4-2462-9698
FAX : +886-4-2462-8002
E-mail : sales@awea.com

ISO 9001



ISO 14001



AGENT

MB SERIES

High Precision Horizontal Boring Mills

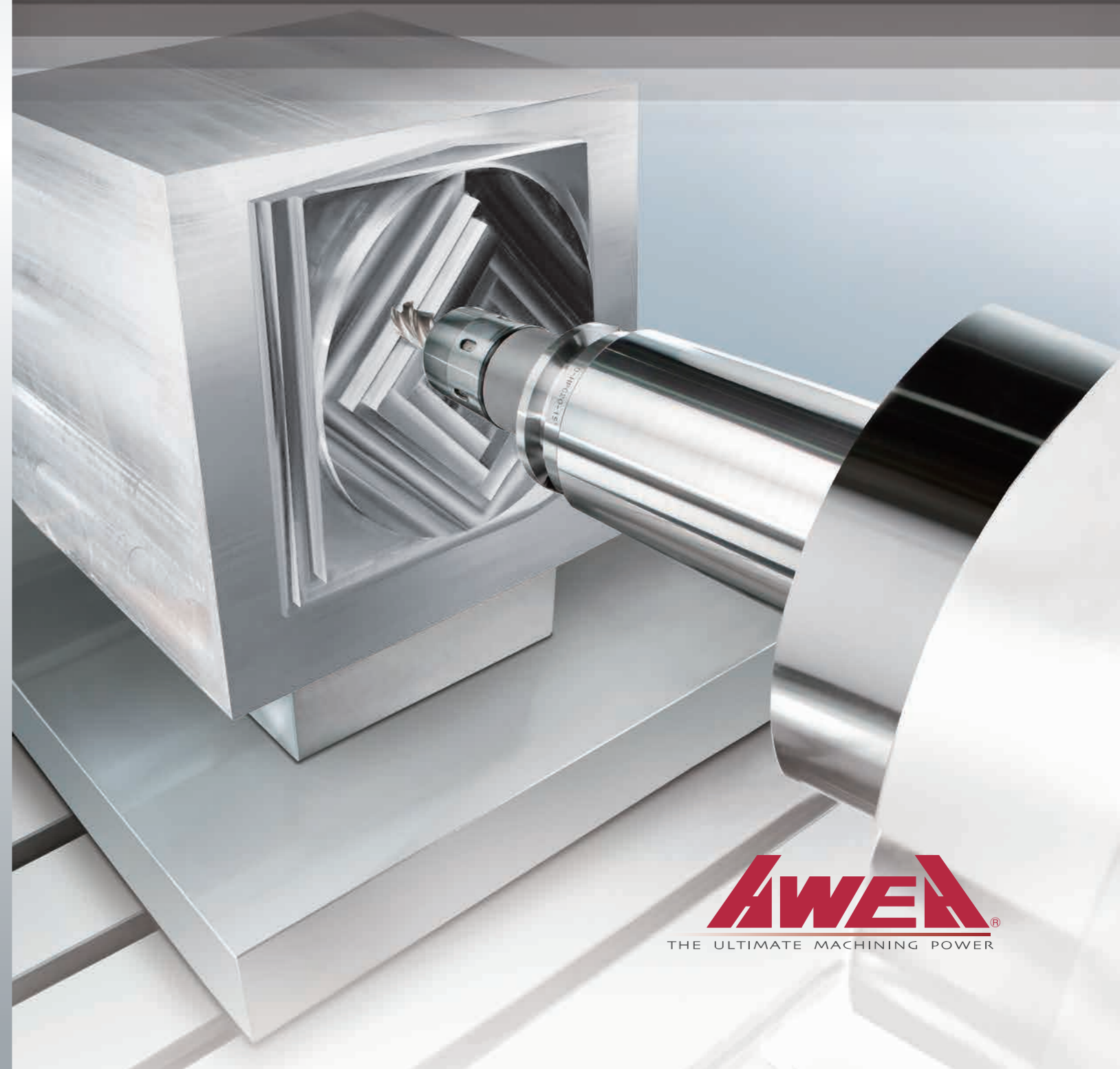

MB Series

High Precision Horizontal Boring Mills

With years of innovation and manufacturing experience on horizontal boring mills, we combine them with the latest technology components to make the MB series provide maximum mechanical performance and strengthen our reputation as a professional boring mills manufacturer.

- High precision spindle with over 1,800 N-m of torque available on the low gear of the 3-step gear head, machining tough material is now a simple task.
- Rotary table is adopted with high rigidity double-layer structure design to provide table load capacity up to 4,000 kg. 1° or 0.001° B-axis minimum indexing is also provided for selection.
- One-piece bed structure plus 4 compound guideways are combined with the X / Y axes high rigidity box way to meet with various needs for heavy-duty cutting and precision machining.
- The open-space operating area can shorten the distance between the operator and the working area to increase both safety and convenience. This compact size machine provides abundant machining capacity with minimum space.

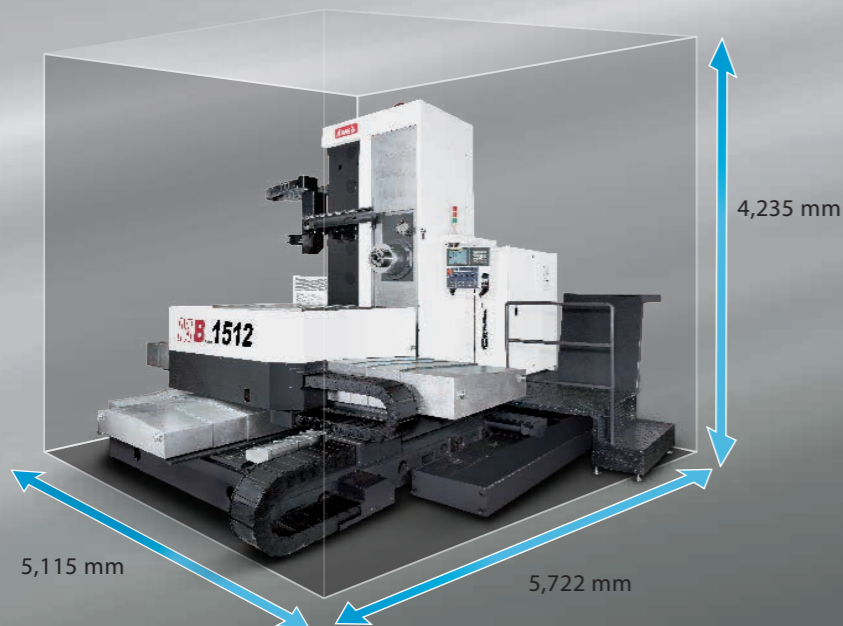

MB Series

High Precision Horizontal Boring Mills

High Rigidity Structure

- The Finite Element Method (FEM) provides optimum machine designing and light-weighted structure advantages while ensuring high machine rigidity.
- Built to withstand years and years of rigorous high production machining, the heavily ribbed, one-piece thermally balanced bed and casting components are of " MEEHANITE " casting.
- The 3 axes feed system is adopted with full travel support and uses high precision linear encoders to ensure optimum performance and accuracy.
 - ▶ The X / Y axes are adopted with high rigidity box way which is pre-heated and pre-grinded, suitable for heavy-duty cutting conditions.
 - ▶ The Z-axis is adopted with 4 compound guideways to effectively prevent the working table from overhanging while providing strong and firm support.



- Large size ball screws are designed with pretension to increase the working accuracy.
- The automatic lubrication system uses pressure-relief lubricators and high quality copper oil pipe which gives the right amount of lubricants to the guide ways, ball screws and other key components.

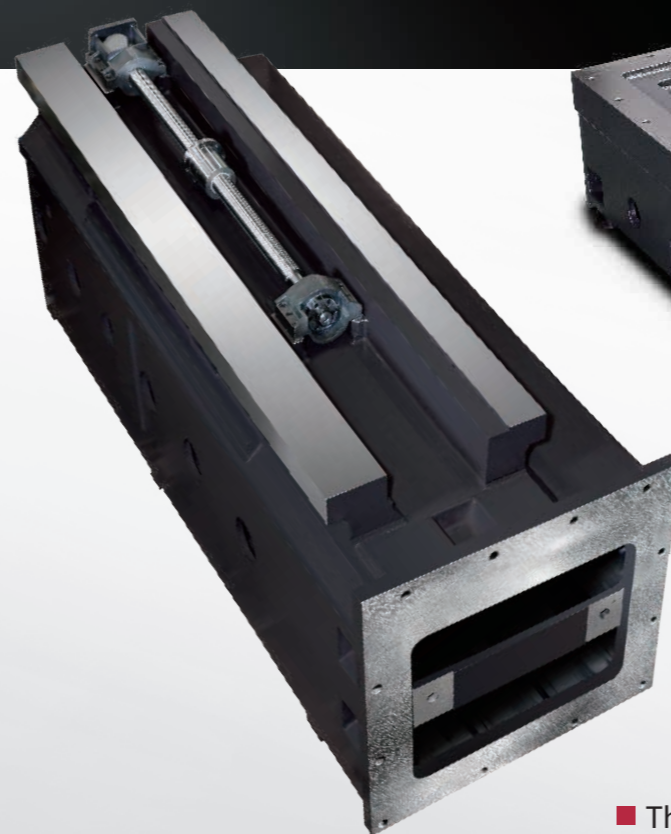

- The contact surface of the bed and column are all precision hand scraped to ensure maximum performance and accuracy.

- The bed and column structure are built in one-piece.



Optimized Spindle System

- High rigidity enclosed spindle head design combined with spindle transmission and feeding system provides powerful heavy-duty cutting ability.
- Max. spindle speed of 3,200 rpm with 3-step gear box can provide maximum torque output of 1,800 N-m under 137 rpm.
- The system uses a Ø110 mm high precision spindle and the W-axis travel to be up to 500 mm.

1,800 N-m

Maximum Torque

- The inner taper of the spindle conforms with BBT50 tool to provide a firmer grip to the tools which reduces the vibration from the tools.

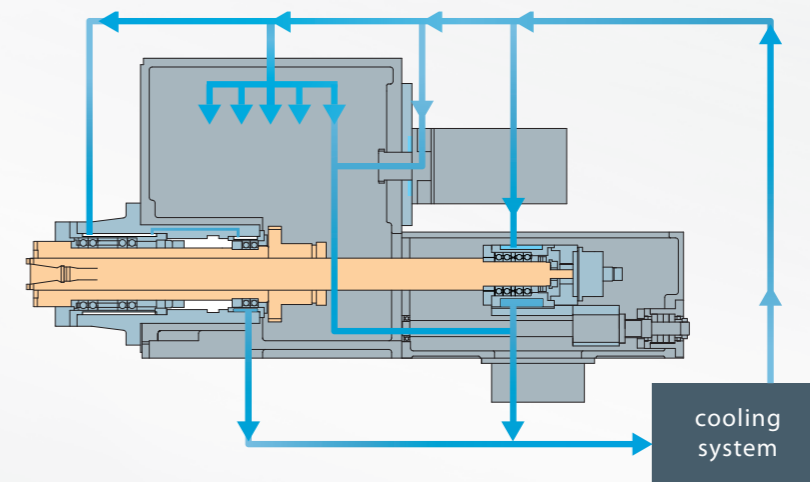
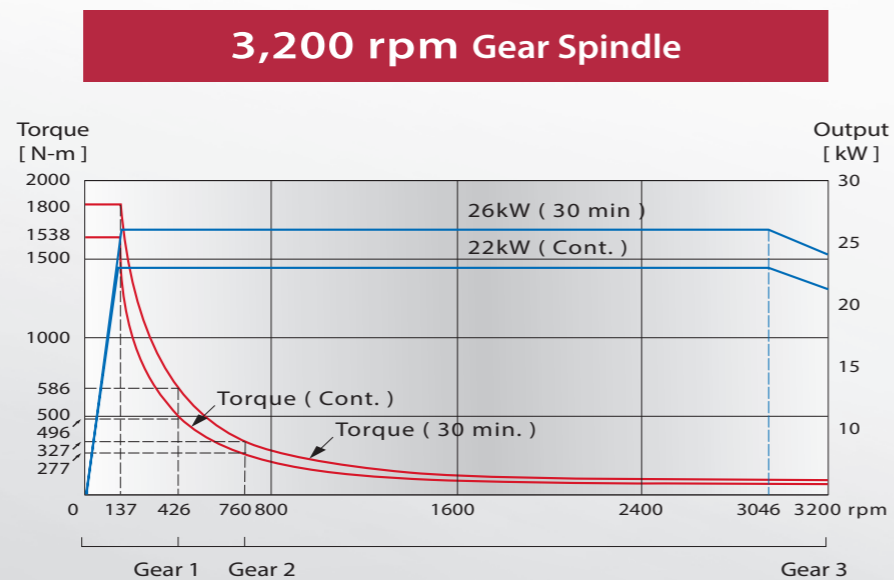
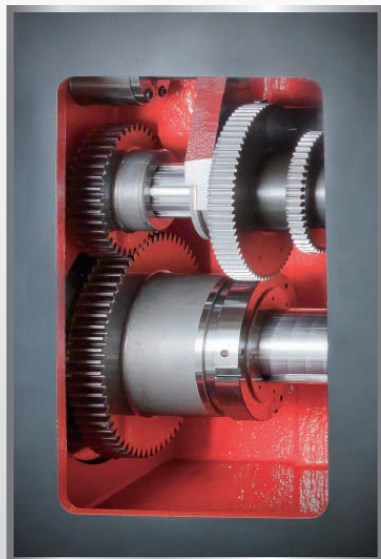
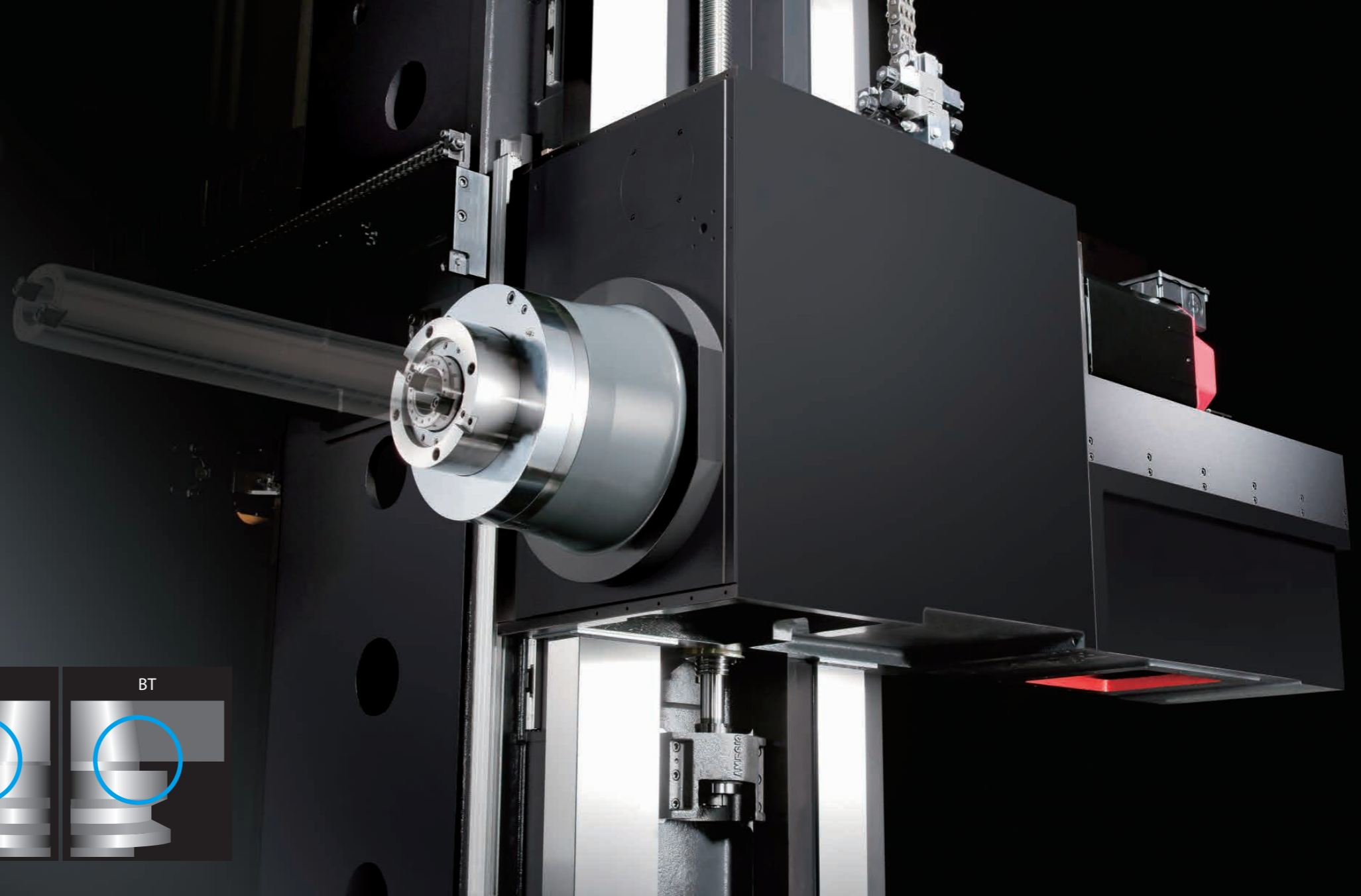
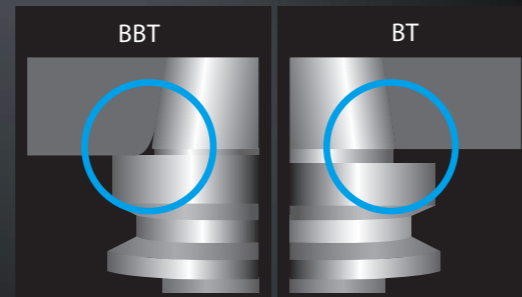

- The spindle cooling system uses oil cooling and water jacket device to give the right amount of coolant to all the bearings, motors, gears inside the spindle box. This effectively reduces spindle thermal distortion and ensures working accuracy.

High Performance Rotary Working Table

Working table is adopted with double layer design to ensure excellent rigid structure and heavy load capability.

4,000 KG

MB Series 1512

Working table specification	
Table size	1,250 x 1,150 mm
Table load capacity	4,000 kg
B-axis rotary range	360°
B-axis indexing	0.001° / 1°
B-axis speed	5 rpm

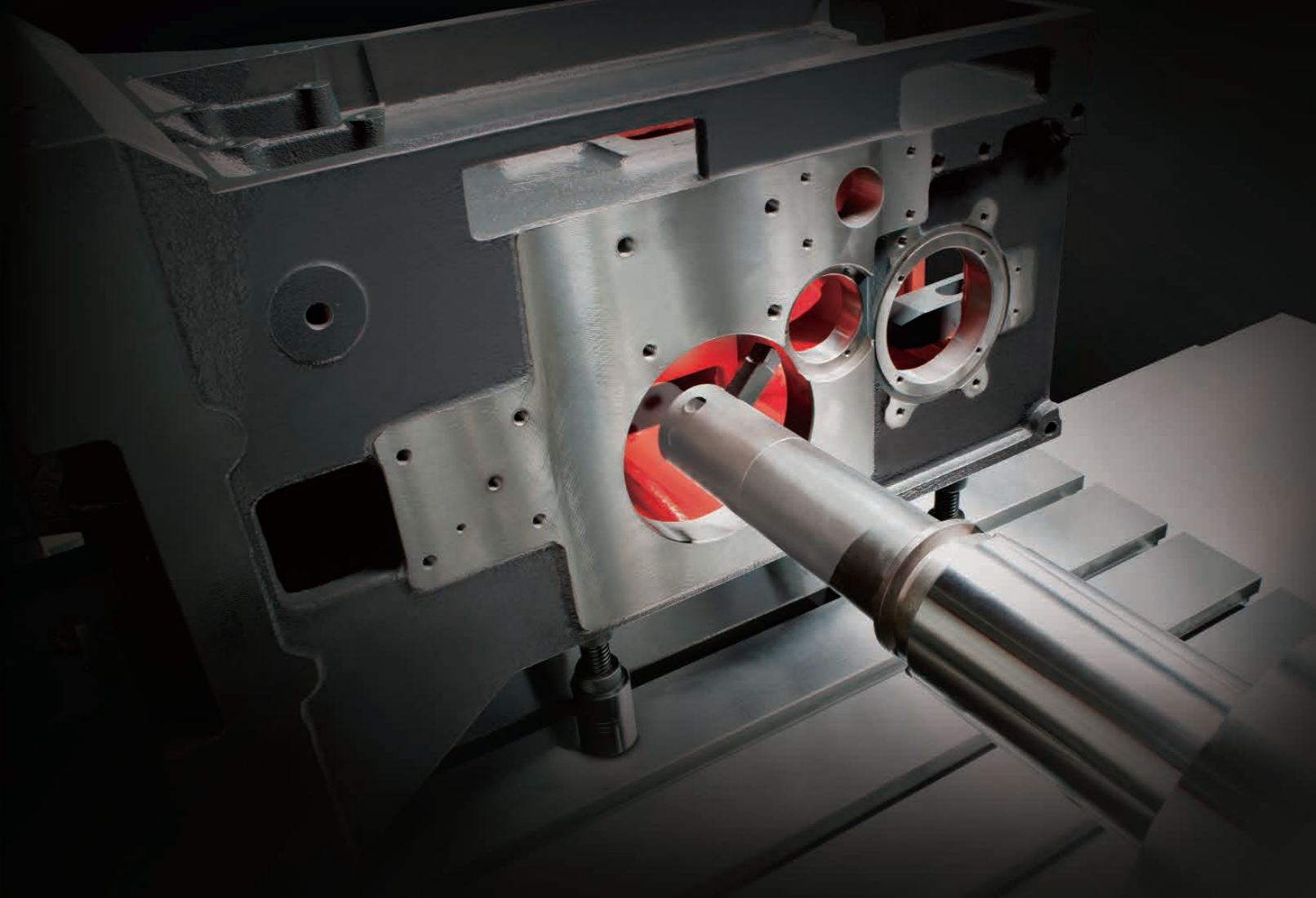

1° B-axis indexing

- 3-piece curvic coupling design that no table lifting is required during table rotation to ensure table positioning accuracy.
- High rigidity taper roller bearing design ensures stable working table indexing.
- Adopted with hydraulic braking system to provide enough holding force for heavy-duty machining.

0.001° B-axis indexing

- High precision 2-piece worm gear design provides low backlash and high accuracy structural features.
- High rigidity taper roller bearing design ensures stable working table indexing.
- Adopted with hydraulic braking system to provide enough holding force for heavy-duty machining.
- Capable of 4th axis simultaneous machining suitable for high precision and complex parts machining.

Optional APC System

Parts loading / unloading during cutting, maximize machine working efficiency.

- Hydraulic clamping system clamp the table after table positioning, and air tight detecting device would ensure the successful locking.



High Efficiency Chip Conveying System

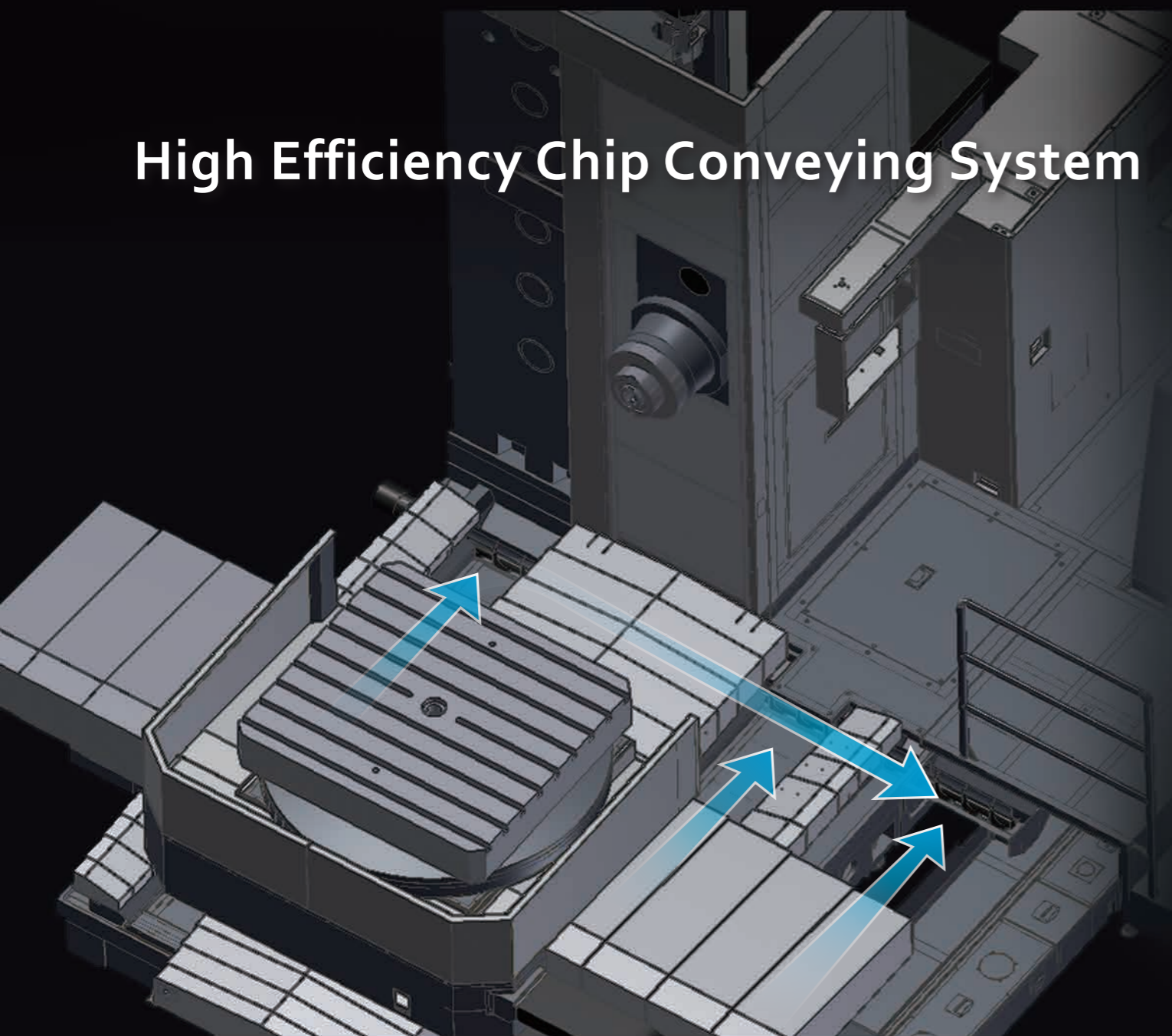

- The carefully designed chips conveying system allows the chips to automatically fall into the screw type chip augers. The chip augers then transports the chips into the water tank and chip conveyor to prevent heat and chips from accumulating which ensures long-term working accuracy.
- 2 sets of chip scoops are installed between the contact surface of the saddle and bed which helps the chips on top of the bed to be quickly transported in to the chip conveyor and also reduces cleaning time.

High Reliability ATC System



- Standard 40T ATC system. 60T magazine is optional.
- Max. tool load is 25 kg, max. tool magazine load is 600 kg which can meet various needs of working condition.

Dimensions

Tool Shank and Pull Stud Dimensions

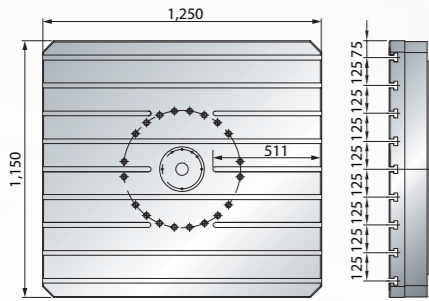

T-slot Dimensions

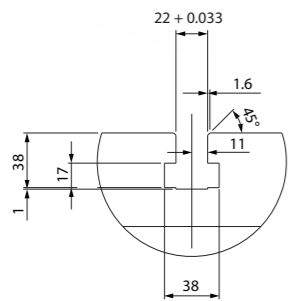

BBT50

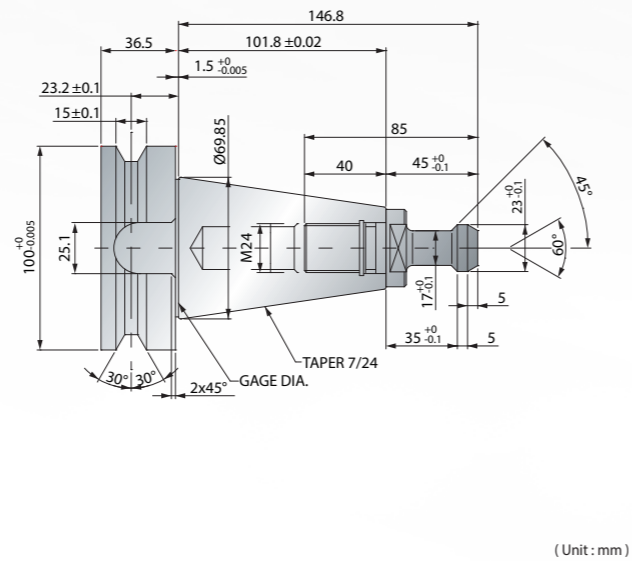

(Unit: mm)

Machine Dimensions

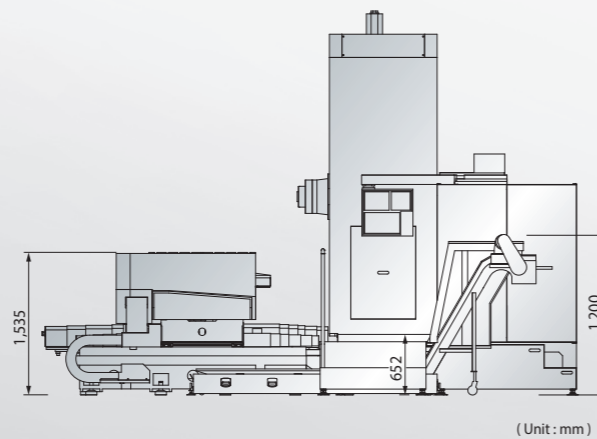
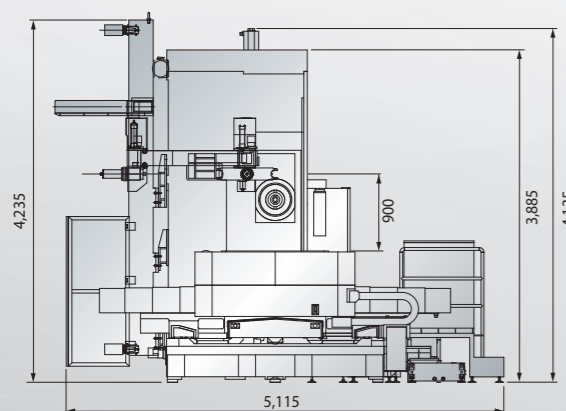
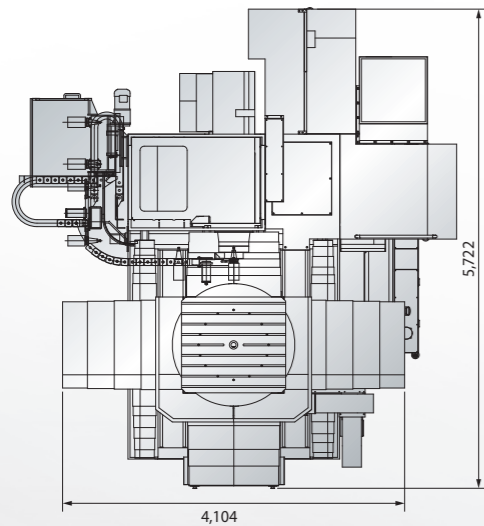

(Unit: mm)

		MB-1512	MB-2012
SPECIFICATIONS			
X / Y / Z axes travel	mm	1,500 / 1,200 / 900	2,000 / 1,200 / 900
W-axis travel	mm	500	
Distance from spindle nose to table center	mm	575 ~ 1,475	
WORKING TABLE			
Table size (X x Y)	mm	1,250 x 1,150	
Table load capacity	kg	4,000	
Minimum table index		0.001°	
B-axis speed	rpm	5	
SPINDLE			
Spindle taper		BBT50	
Boring spindle size	mm	Ø 110	
Spindle motor (cont. / 30 min.)	kW (HP)	22 / 26 (30 / 35)	
Spindle speed	rpm	3,200	
Spindle torque	Nm	1,800	
FEED RATE			
X / Y / Z axes rapid feed rate	m/min.	15 / 15 / 15	
W-axis rapid feed rate	m/min.	6	
Cutting feedrate	m/min.	6	
TOOL MAGAZINE			
Tool magazine capacity	T	40	
Max. tool length (from gauge line)	mm	400	
Max. tool weight	kg	25	
Max. tool diameter / adj. pocket empty	mm	Ø 125 / Ø 250	
ACCURACY			
Positioning accuracy (JIS B 6338)	mm	± 0.01 / Full Travel	
Positioning accuracy (VDI 3441)	mm	P ≤ 0.02 / Full Travel	
Repeatability (JIS B 6338)	mm	± 0.003	
Repeatability (VDI 3441)	mm	P ≤ 0.008	
GENERAL			
Power requirement	kVA	60	
Pneumatic pressure requirement (min.)	kg/cm ²	5	
Hydraulic unit tank capacity (pump)	liter (HP)	200 (3)	
Lubrication oil tank capacity	liter	8	
Coolant tank capacity (pump)	liter (HP)	330 (1)	
Machine weight	kg	30,000	33,000

Specifications are subject to change without notice.

Standard Accessories

- FANUC Oi-MF control
- 3-step gear spindle
- Standard splash guard + chip collector for table
- Spindle cooling system
- X / Y / Z / B axes optical linear scale
- 0.001° indexing rotary table
- Automatic power off system
- Caterpillar type chip conveyor and bucket
- Coolant equipment system (Pump & tank)
- Heat exchanger for electrical cabinet
- Air gun
- Alarm light
- Centralized automatic lubricating system
- Foundation bolt kit

Optional Accessories

- FANUC 31 i control
- Automatic pallet changer
- Half enclosed / Fully enclosed splash guard
- Oil skimmer
- A / C cooler for electrical cabinet
- Transformer
- 60T Arm type tool magazine
- Coolant through the spindle (Form A)