



AWEA MECHANTRONIC CO., LTD.

HEADQUARTERS
629, Suezhetou Section, Kwanpu Rd., Wenshan Li,
Hsinpu, Hsinchu 305, Taiwan
TEL : +886-3-588-5191
FAX : +886-3-588-5194
Website : www.awea.com

CENTRAL TAIWAN SCIENCE PARK BRANCH
15, Keyuan 2nd Rd., Central Taiwan Science Park,
Taichung 407, Taiwan
TEL : +886-4-2462-9698
FAX : +886-4-2462-8002
E-mail : sales@awea.com



FMV-99 SERIES

Gantry Type 5-Axis Machining Centers

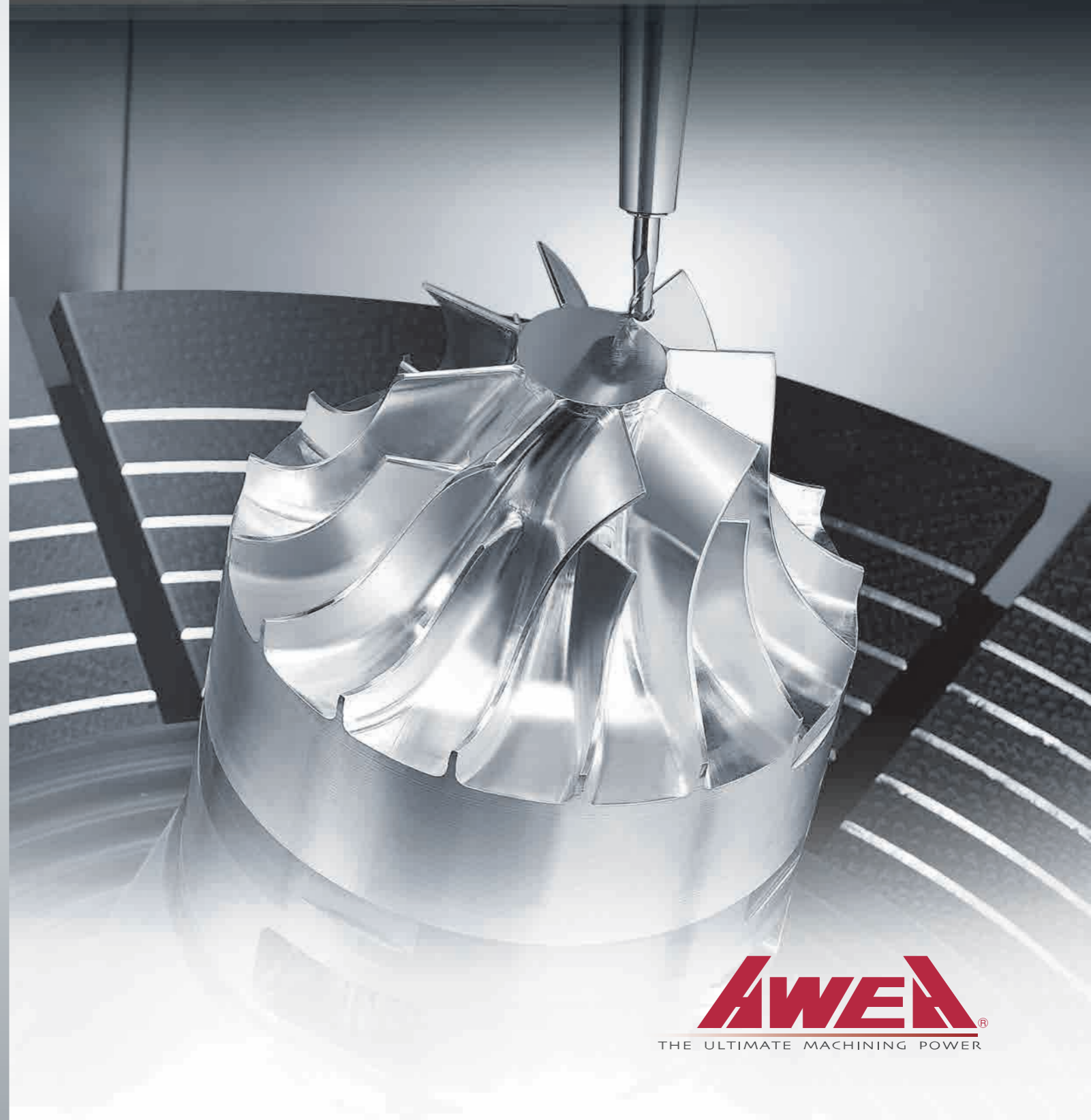



Gantry Type 5-Axis Machining Centers

Based customer feedback and latest technology evolvement. AWEA introduce the latest version FMV-99. Performance, reliability and ergonomic design has been completed upgraded.

FMV series can work on side cutting with short tool.

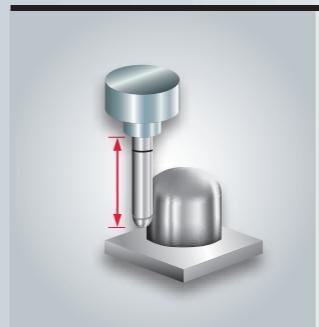

3-axis cutting

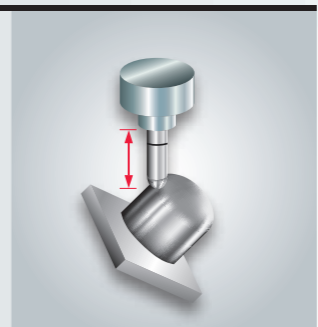

5-axis cutting

FMV series can work on side-filler cutting.



3-axis cutting

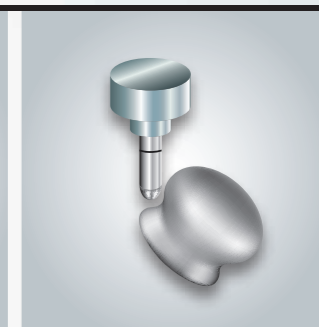

5-axis cutting



FMV-99 SERIES

Gantry Type 5-Axis Machining Center

High rigidity gantry type structure features high performance A,C axes swivel table, which allows FMV-99 series easily overcome integrated complex tasks with milling, drilling, tapping, fixed slanted angle machining, helical machining and intricate shape machining.

- High performance A, C axes swivel table. A-axis swing range $-120^{\circ} \sim +30^{\circ}$, C-axis rotary range 360° , table load capacity 1,000 kg.*¹
- Built-in spindle can export 100% motor output, which provides energy saving, lower noise and higher accuracy.
- X / Y / Z axes adopt high power direct drive servo motor. Rapid feed rate is up to 48 m/min.
- 40T / 80T arm type ATC fulfills various machining needs.
- The optimal exterior design allows work-piece to be easily loaded via overhead crane, which phenomenally enhances production efficiency.

*1 : 0° : 1,000 kg / 90° : 700 kg



FMV-99 SERIES

Gantry Type 5-Axis Machining Center

High rigidity gantry type structure and advanced core components achieve high efficiency and high accuracy machining capacity.

- X-axis adopts AWEA "simultaneous-controlled technology" which greatly reduces accuracy error caused by both sides of ball screws.
- One-piece U-shaped high rigidity base adopts FC300 MEEHANITE casting, which is stronger than competitor's 3-piece structure.
- Minimal spindle overhang design can prevent deformation of overhang to ensure cutting rigidity and stable accuracy.
- X / Y / Z axes adopt heavy-duty roller type linear guide ways design, which provide integration of heavy cutting ability from box way and fast movement ability from linear guide way.
- X / Y / Z axes are driven by superior HEIDENHAIN QSY absolute servo motor, provides faster acceleration / deceleration and powerful thrust.

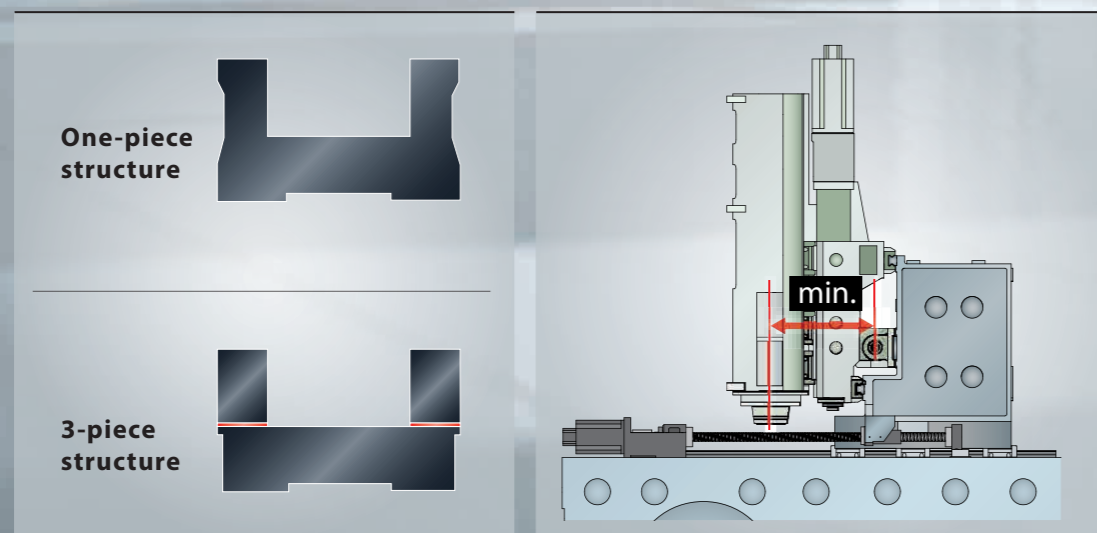
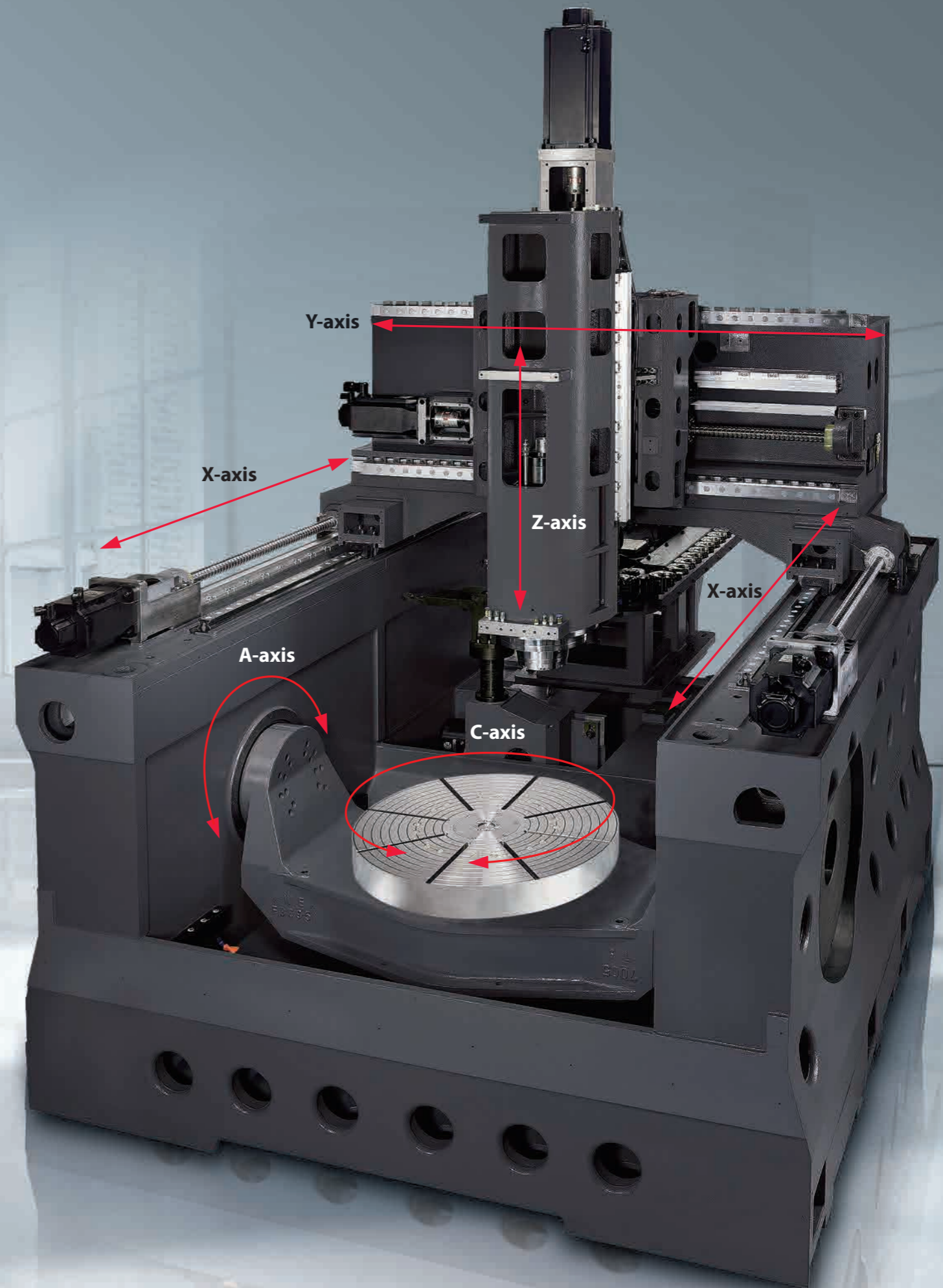

High Performance Swivel Table

A-axis

- A-axis is driven by high class servo motor that provides the max. torque 12,600 N-m.
- Brake system adopts servo motor with stacked disk spring design to provide stable and reliable performance. Even when the power is cut off suddenly, table could still hold at current position thus greatly improves the safety.

C-axis

- C-axis is driven by direct drive motor (DDM), which motion can be delivered 100% from motor to provide high speed, high torque and zero backlash.
- Outer diameter is increased 35% compared to the last generation, and rigidity of C-axis is improved 70%.
- Brake system adopts specialized mechanical design, provide ample braking force.

The Finite Element Analysis (FEA)

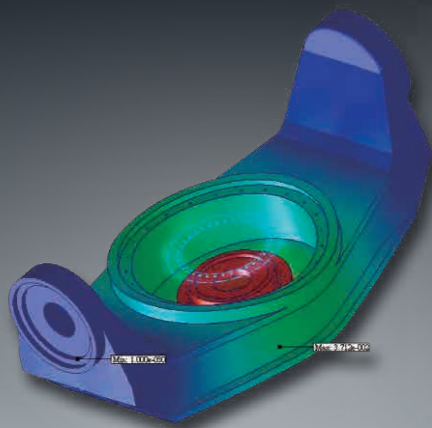

3D CAD Design

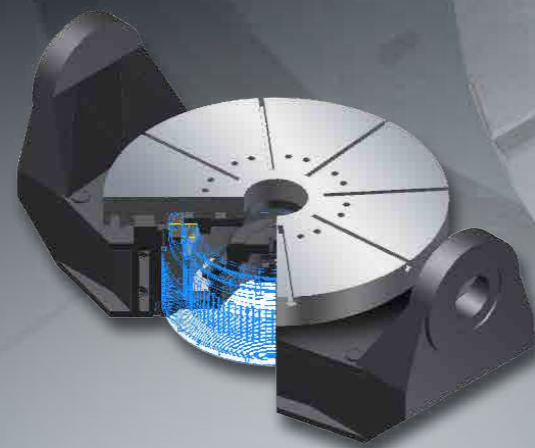

16,000 RPM Built-in spindle

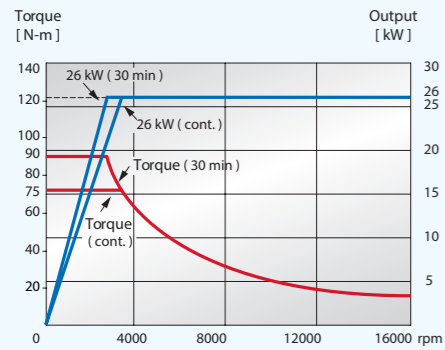

22,000 RPM Built-in spindle

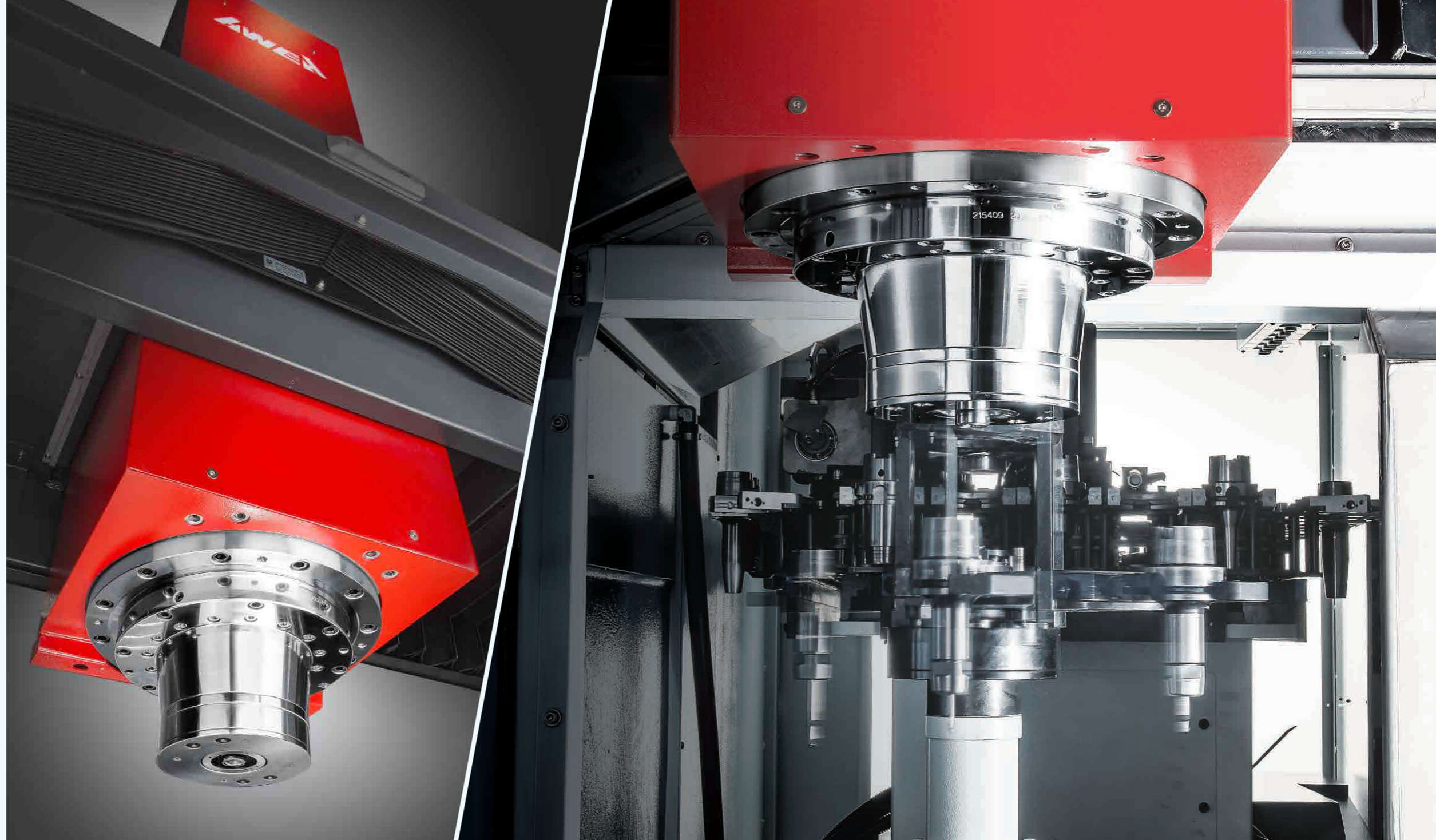
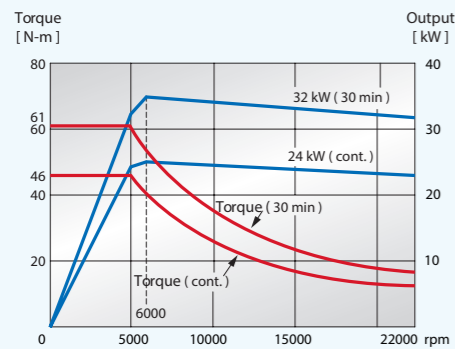

Ultimate Machining Power

- 16,000 / 22,000 rpm high speed built-in spindle can export 100% motor output, which provides lower noise and higher accuracy to fulfill dies & molds machining needs.
- Spindle bearing adopts high precision P4 ceramic bearings with optimal span two-points support design, which can sustain huge torque force while long-term machining to remain high accuracy.

Machining Capacity

	Tool diameter (mm)	Spindle speed (rpm)	Feed rate (mm)	Cutting depth (mm)	Cutting width (mm)	Feed rate / Blade (mm)	Spindle load (%)
High speed drilling	Ø 40	70	90	20	-	0.13	35
Tapping	M42*4.5	50	225	20	-	-	-
Heavy cutting	Ø 50	2,000	10,000	1	32	1	82

High Speed ATC System

- Standard equipped 40T (80T opt.) arm type ATC system. Tool change efficiently greatly reduce tool changing time.
- Short cut tool path perform tool change swiftly and improve machining efficiency.
- Enclosed ATC guard design can avoid contamination of cutting process.

Advance Control System

- NC control system features HEIDENHAIN iTNC 530 provide excellent capacity like high speed, high precision and surface evenness.
- AWEA *i* Console function offers instant status and abundant interactive features for smart machining. (opt.)

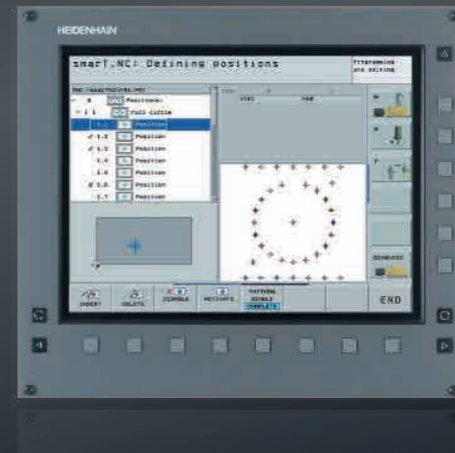

FM-99 High Speed Machining Series

Fully enclosed splash guard with dust collector and fixed table provide most suitable combination for cutting high accuracy components based on dusty materials like graphite.

i Console

Main screen

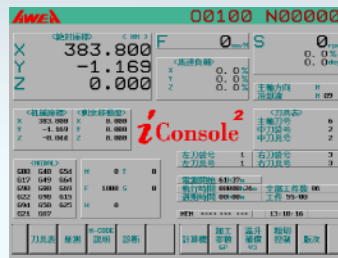

Manual tool length measurement

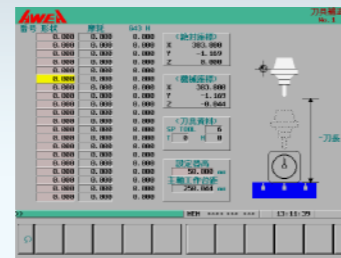

Auto. tool length measurement



Circular work-piece measurement



Basic rectangular work-piece measurement



Advanced rectangular work-piece measurement



Adaptive feed control (AFC) (Opt.)

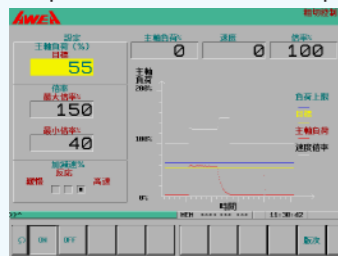

CNC parameter optimization (Opt.)



Spindle thermal compensation (Opt.)

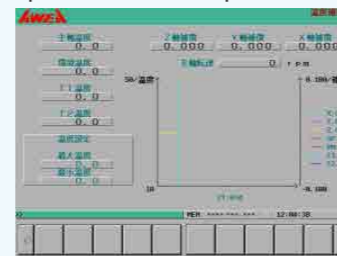

Tools management



Trouble shooting



Counter



Standard and optional accessories

Back / side-exit chips conveyors



X / Y / Z linear scale



Air conditioner for electric cabinet



Coolant nozzles around spindle



Coolant through spindle

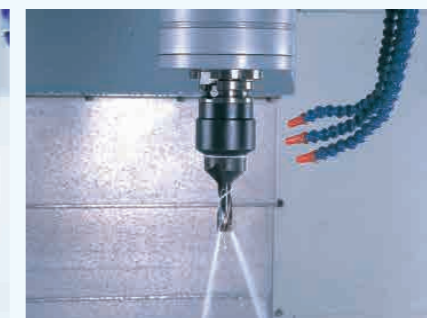

Tool length measurement



Dimensions

Table Dimensions

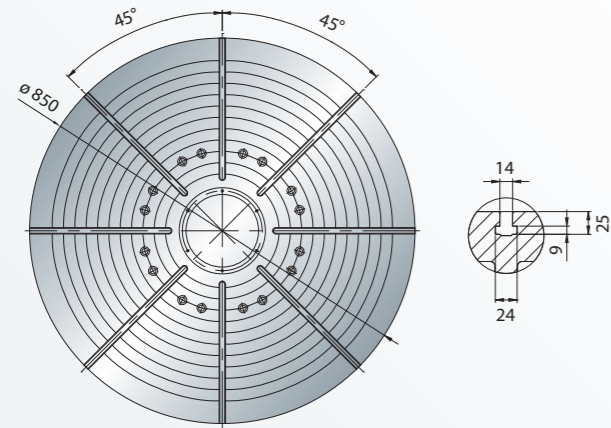

Work-piece Dimensions

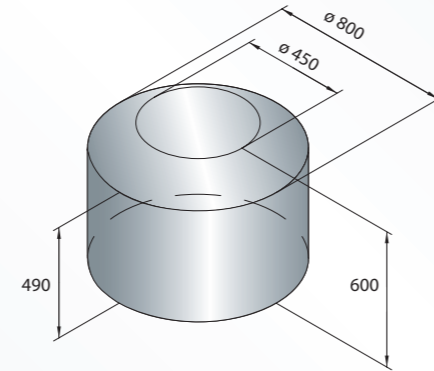

Interference Diagram

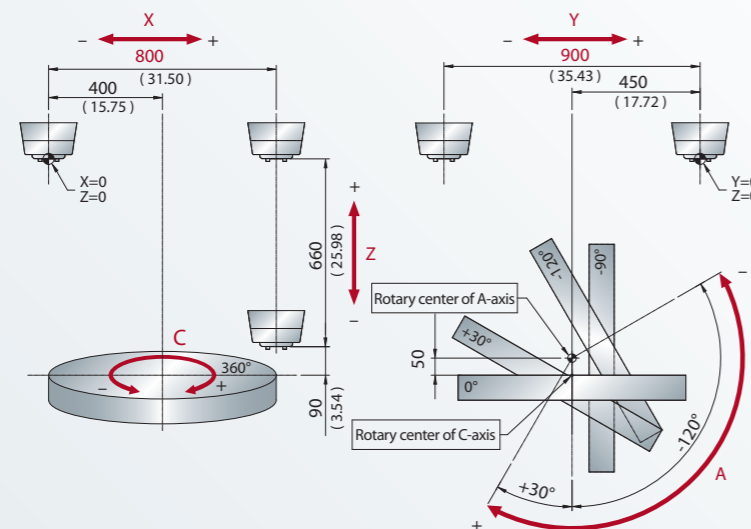

Machine Dimensions

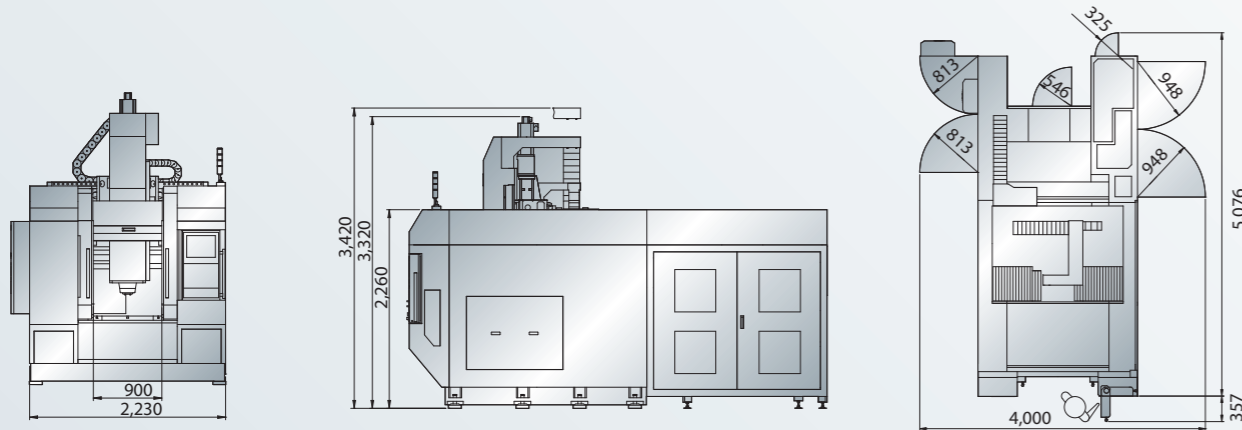

(Unit : mm)

FM-99 High speed series

FMV-99 5-axis series

Specification		FM-99 High speed series	FMV-99 5-axis series
X-axis travel (right-left)	mm	900	800
Y-axis travel (back-forth)	mm		900
Z-axis travel (up-down)	mm		660
Distance from spindle nose to table top	mm	150 ~ 810	90 ~ 750
Working table			
Table size	mm	1,060 x 900 (X x Y)	Ø 850
T-slot size	mm	14 x 9 x 100	14 × 8 × 45°
Table load capacity	kg	2,500	0° : 1,000 kg / 90° : 700 kg
Spindle			
Spindle speed	rpm	Built-in spindle 16,000	
Spindle taper		BT 40	
Spindle motor output (cont. / 30 min)	kW	26	
Axes			
Swiveling range of A-axis		-	A-axis : -120° ~ +30°
Rotary range of C-axis		-	360°
Swiveling speed of A-axis	rpm	-	30
Rotary speed of C-axis	rpm	-	100
Cutting feed rate	m / min.	24	
Rapid feed rate (X / Y / Z)	m / min.	48	
Tool Magazine			
ATC type		Arm type	
Tool magazine capacity		40T	
Max. tool diameter / adj. pocket empty	mm	Ø 90 / 125	
Max. tool length	mm	300	
Max. tool weight	kg	8	
General			
CNC control		FANUC 31i	HEIDENHAIN iTNC 530
Coolant tank capacity	L	500	
Air requirement	kg / cm ²	6	
Power requirement	k VA	65	90
Machine weight	kg	13,000	15,000
Dimensions (L × W × H)	mm	4,530 × 2,230 × 3,420	

Specifications are subject to change without notice.

Standard Accessories

- Chip conveyor (back / side-exit)
- X / Y / Z linear scale
- Air conditioner for electric cabinet
- Oil mist cooling system
- Coolant nozzles around spindle
- Spindle cooling system
- Centralized automatic lubricating system
- Fully enclosed splash guard
- Coolant system with pump and tank
- Heat exchanger for electrical cabinet

- Adjusting tools & tool box
- Air gun system
- Alarm light
- Automatic power off system
- Leveling bolts & pads

Optional Accessories

- 22,000 rpm built-in spindle
- 80 T arm type ATC
- Automatic tool length measurement
- Dust collector
- Oil skimmer
- Oil mist collector
- Oil Mist Lubrication System
- Coolant cooling device
- Coolant through spindle (Form A)
- Disc type oil skimmer