

High Precision / High Efficiency
High Durability / Perfection



YES! WE ARE HONOR!

CNC Product Line Up

CNC Vertical Lathe / CNC Vertical Turning Center

HONOR SEIKI Co., Ltd.

www.honorseiki.com.tw



HONOR SEIKI Co., Ltd.

No. 6, Sec. 2, Chungshan Rd., Hunei Dist., Kaohsiung City, 82942 Taiwan
 TEL : +886 7 975 9888 / FAX : +886 7 975 9999
 e-mail : honor@honorseiki.com.tw <http://www.honorseiki.com.tw>



Agent:

VL-46A ~ VL-100A

Spec. / Model	unit	VL-46A	VL-66A	VL-86A	VL-100A
Max. swing dia.	mm	560 (22")	800 (31.5")	1000 (39.4")	1320 (52")
Max. turning dia.	mm	560 (22")	760 (29.9")	860 (33.9")	1100 (43.3")
Max. turning height	mm	450 (17.7")	750 (29.5")	810 (31.9")	1000 (39.4")
Spindle bearing dia.	mm	120 (4.7")	160 (6.3")	200 (7.9")	200 (7.9")
Spindle speed	rpm	25-2500	25-2000	25-1500	5-850
Chuck dia.	mm	305 (12")	475 (18")	533 (21")	1000 (40")
Number of tool position	pcs	12	12	12	12

※ For G/H/M type models, please contact sales representatives.



VL-66C/CM ~ VL-100C/CM

Spec. / Model	unit	VL-66C/CM	VL-86C/CM	VL-100C/CM
Max. swing dia.	mm	850 (33.5")	950 (37.4")	1200 (47.2")
Max. turning dia.	mm	850 (33.5")	950 (37.4")	1200 (47.2")
Max. turning height	mm	650 (25.6")	650 (25.6")	650 (25.6")
Spindle speed	rpm	5-700	5-600	3-400
Chuck dia.	mm	610 (24")	800 (Table)	1000 (Table)
ATC	pcs	12	12	12
Live tool speed (CM)	rpm	50-2250	50-2250	50-2250



VL-46AT/MT ~ VL-86AT/MT

Spec. / Model	unit	VL-46AT/MT	VL-66AT/MT	VL-86AT/MT
Max. swing dia.	mm	560 (22")	800 (31.5")	1000 (39.4")
Max. turning dia.	mm	560 (22")	760 (29.9")	860 (33.9")
Max. turning height	mm	450/380 (17.7"/15")	750/650 (29.5"/25.5")	810/700 (31.9"/27.5")
Spindle bearing dia.	mm	120 (4.7")	160 (6.3")	200 (7.9")
Spindle speed	rpm	25-2500	25-2000	25-1500
Chuck dia.	mm	305 (12")	457 (18")	533 (21")
Number of tool position	pcs	12 + 12	12 + 12	12 + 12



VL-125C/CM ~ VL-250C/CM

Spec. / Model	unit	VL-125C/CM	VL-160C/CM	VL-200C/CM	VL-250C/CM
Max. swing dia.	mm	1600 (63")	2000 (78.7")	2500 (98.4")	3000 (118.1")
Max. turning dia.	mm	1600 (63")	2000 (78.7")	2500 (98.4")	2970 (116.9")
Max. turning height	mm	1200 (47.2")	1200 (47.2")	1600 (63")	1600 (63")
Spindle speed	rpm	3-300	3-250	5-200	5-160
Table dia.	mm	1250 (49.2")	1600 (62.9")	2000 (78.7")	2500 (98.4")
ATC	pcs	12/16	12/16	12/16	12/16
Live tool speed (CM)	rpm	50-2250	50-2250	50-2250	50-2250



HL-26AT/32AT

Spec. / Model	unit	HL-26AT	HL-32AT
Max. turning dia.	mm	260 (10")	400 (15.7")
Max. turning height	mm	180 (7")	230 (9.1")
Spindle bearing dia.	mm	85 (3.3")	120 (4.7")
Spindle speed	rpm	25-4500	25-3500
Chuck dia.	mm	203 (8")	254 (10")
Number of tool position	pcs	12T + 12T	10T + 10T



VL-300C/CM ~ VL-600C/CM

Spec. / Model	unit	VL-300C/CM	VL-400C/CM	VL-500C/CM	VL-600C/CM
Max. swing dia.	mm	3600	4500	6000	7000
Max. turning dia.	mm	3600	4500	6000	7000
Max. turning height	mm	2000	2000	2600	2600
Table dia.	mm	3000	4000	5000	6000
Spindle speed	rpm	1-120	1-85	1-50	1-20
ATC	pcs	16 / 20	16 / 20	16 / 24	16 / 24
Live tool speed (CM)	rpm	50-2250	50-2250	50-2250	50-2250
Max. Table Load	kg	30000	40000	80000	100000



VSC-5080CM ~ VSC-8016CM

Spec. / Model	unit	VSC-5080CM	VSC-8016CM
Max. swing dia.	mm	10000	16000
Max. turning dia.	mm	10000	16000
Max. turning height	mm	4500	4750
Table dia.	mm	5000	8000
Table speed	rpm	1-50	1-25
ATC	pcs	16	16
Live tool speed	rpm	50-2250	50-2250
Max. Table Load	kg	80000	120000

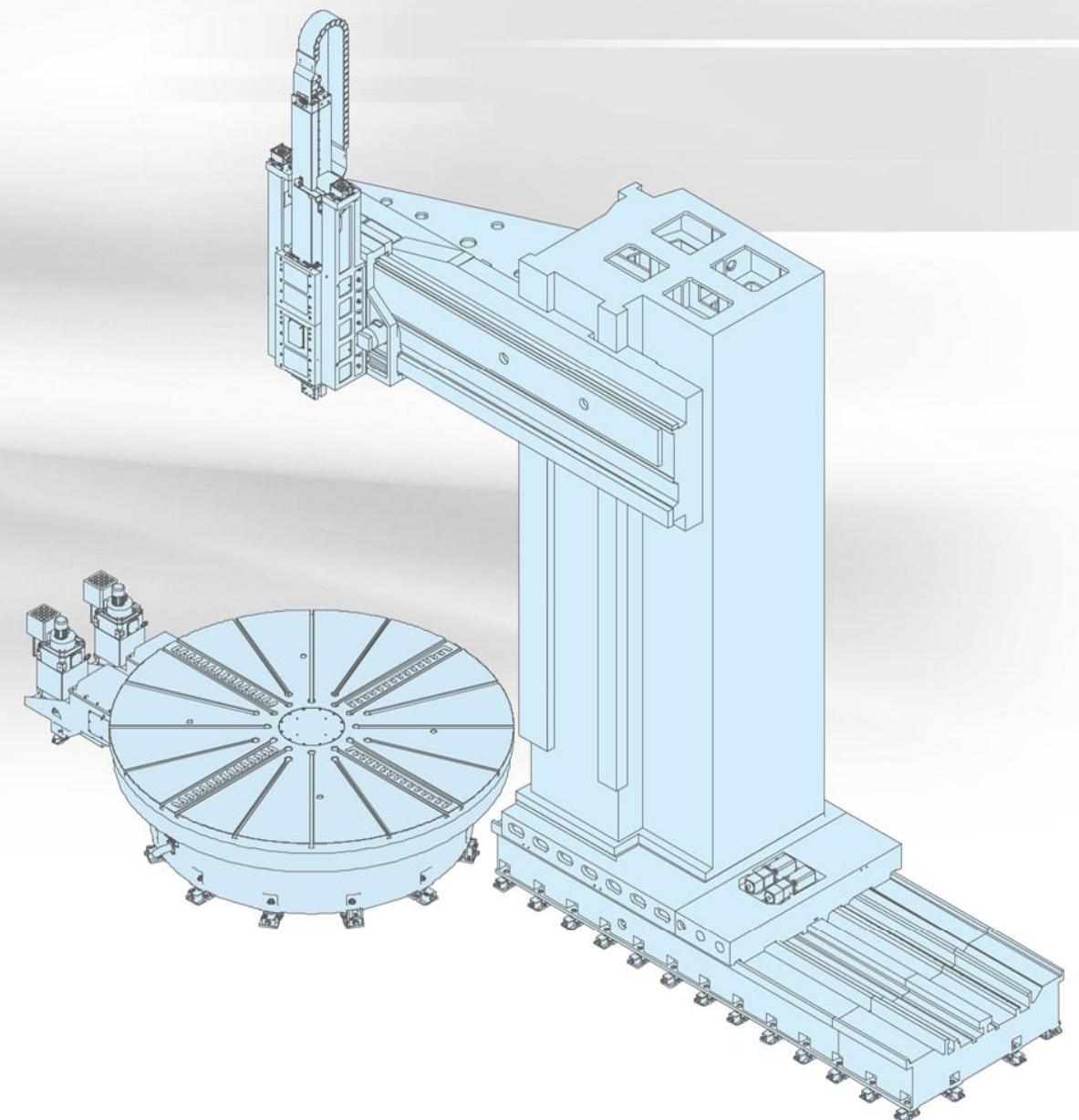

Planar Turning Center

(Vertical Turning Center with Y Axis)

PL Series

Spec. / Model	unit	PL-160CM	PL-200CM	PL-250CM	PL-300CM	PL-350CM	PL-400CM	PL-500CM
Max. swing dia.	mm	2000	2500	3000	3600	4000	4500	6000
Max. turning dia.	mm	2000	2500	3000	3600	4000	4500	6000
Max. turning height	mm	1170	1600	1600	2000	2000	2000	2600
Table dia.	mm	1600	2000	2500	3000	3500	4000	5000
Table speed	rpm	250	200	160	120	100	85	50
ATC	pcs	R16+L60	R16+L60	R16+L60	R16+L60	R16+L60	R16+L60	R16+L60
Y axis travel	mm	2000	2500	3000	3600	4000	4500	6000

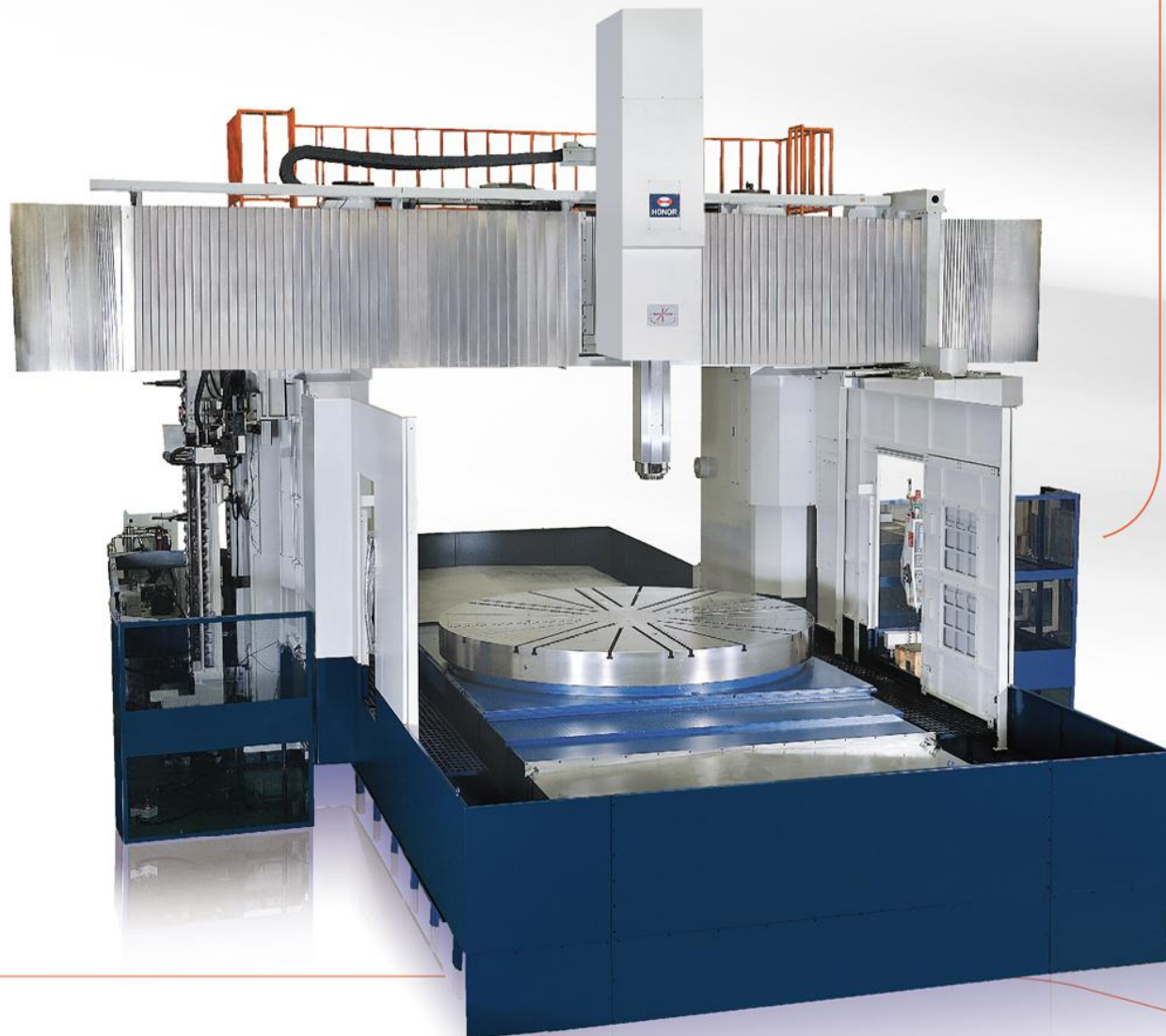

VG Series CNC Vertical Grinding Machine

VG-120GN/GB ~ VG-250GN/GB

Spec. / Model	unit	VG-120GN	VG-120GB	VL-160GN	VL-160GB	VL-200GN	VL-200GB	VL-250GN	VL-250GB
Max. swing dia.	mm	1400		1800		2200		2700	
Max. turning dia.	mm	1200		1600		2000		2500	
Max. turning height	mm	500		500		700		700	
Table dia.	mm	1200		1600		2000		2500	
Table speed	rpm	0-100		0-50		0-50		0-50	
B-axis travel	pcs	-	±45°	-	±45°	-	±45°	-	±45°
Wheel speed	rpm	0-6000		0-6000		0-6000		0-6000	
Max. Table load	kg	2000		4000		8000		12000	

